

Q. 1 – Q. 5 carry one mark each.

Q.1 If I were you, I _____ that laptop. It's much too expensive.

- (A) won't buy (B) shan't buy
(C) wouldn't buy (D) would buy

Q.2 He turned a deaf ear to my request.

What does the underlined phrasal verb mean?

- (A) ignored (B) appreciated (C) twisted (D) returned

Q.3 Choose the most appropriate set of words from the options given below to complete the following sentence.

_____ is a will, _____ is a way.

- (A) Wear, there, their (B) Were, their, there
(C) Where, there, there (D) Where, their, their

Q.4 $(x \% \text{ of } y) + (y \% \text{ of } x)$ is equivalent to _____.

- (A) 2 % of xy (B) 2 % of $(xy/100)$ (C) xy % of 100 (D) 100 % of xy

Q.5 The sum of the digits of a two digit number is 12. If the new number formed by reversing the digits is greater than the original number by 54, find the original number.

- (A) 39 (B) 57 (C) 66 (D) 93

Q. 6 – Q. 10 carry two marks each.

- Q.6 Two finance companies, P and Q, declared fixed annual rates of interest on the amounts invested with them. The rates of interest offered by these companies may differ from year to year. Year-wise annual rates of interest offered by these companies are shown by the line graph provided below.

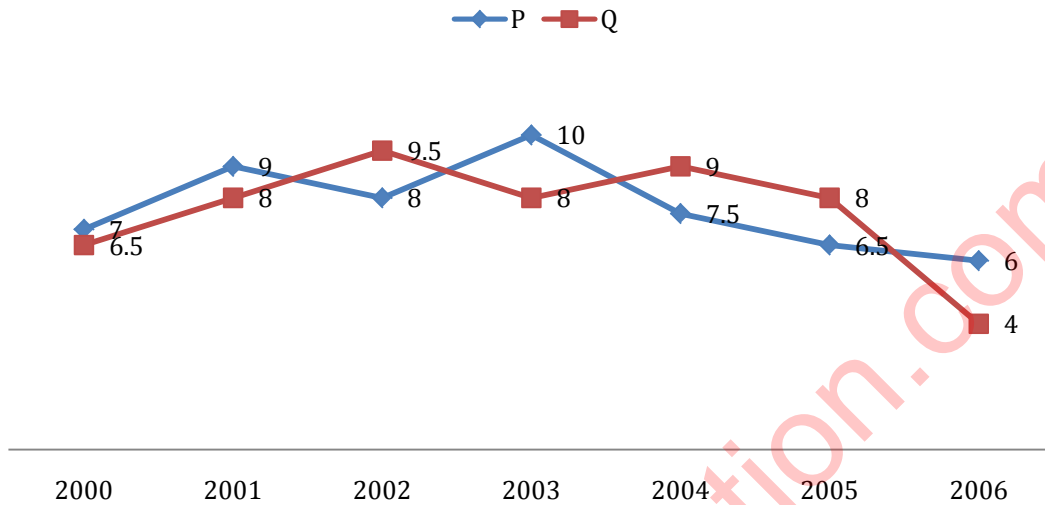

If the amounts invested in the companies, P and Q, in 2006 are in the ratio 8:9, then the amounts received after one year as interests from companies P and Q would be in the ratio:

- (A) 2:3
 (B) 3:4
 (C) 6:7
 (D) 4:3
- Q.7 Today, we consider Ashoka as a great ruler because of the copious evidence he left behind in the form of stone carved edicts. Historians tend to correlate greatness of a king at his time with the availability of evidence today.

Which of the following can be logically inferred from the above sentences?

- (A) Emperors who do not leave significant sculpted evidence are completely forgotten.
 (B) Ashoka produced stone carved edicts to ensure that later historians will respect him.
 (C) Statues of kings are a reminder of their greatness.
 (D) A king's greatness, as we know him today, is interpreted by historians.

- Q.8 Fact 1: Humans are mammals.
Fact 2: Some humans are engineers.
Fact 3: Engineers build houses.

If the above statements are facts, which of the following can be logically inferred?

- I. All mammals build houses.
II. Engineers are mammals.
III. Some humans are not engineers.

- (A) II only. (B) III only.
(C) I, II and III. (D) I only.

- Q.9 A square pyramid has a base perimeter x , and the slant height is half of the perimeter. What is the lateral surface area of the pyramid?

- (A) x^2 (B) $0.75x^2$ (C) $0.50x^2$ (D) $0.25x^2$

- Q.10 Ananth takes 6 hours and Bharath takes 4 hours to read a book. Both started reading copies of the book at the same time. After how many hours is the number of pages **to be** read by Ananth, twice that **to be** read by Bharath? Assume Ananth and Bharath read all the pages with constant pace.

- (A) 1 (B) 2 (C) 3 (D) 4

END OF THE QUESTION PAPER

Useful Data:

Gas constant (R)	8.314 J.mol ⁻¹ K ⁻¹
Acceleration due to gravity (g)	9.81 m ² .s ⁻¹
Atomic weight of oxygen	16 g.mol ⁻¹
Atomic weight of silicon	28 g.mol ⁻¹
Atomic weight of iron	56 g.mol ⁻¹

Q. 1 – Q. 25 carry one mark each.

- Q.1 For the transformation shown below, if one of the eigenvalues is 6, the other eigenvalue of the matrix is _____

$$\begin{bmatrix} X \\ Y \end{bmatrix} = \begin{bmatrix} 5 & -2 \\ -2 & 2 \end{bmatrix} \begin{bmatrix} x \\ y \end{bmatrix}$$

- Q.2 The solution of the differential equation

$$\frac{d^2y}{dx^2} = \frac{dy}{dx} \text{ is}$$

- (A) $y = e^x + C$ (B) $y = e^{-x} + C$
 (C) $y = C_1 e^{-x} + C_2$ (D) $y = C_1 e^x + C_2$

[where, C, C₁ and C₂ are constants]

- Q.3 If $\vec{V} = x^2y \hat{i} + y^2x \hat{j} + xyz \hat{k}$, the divergence of \vec{V} is

- (A) $x^3y + y^3x + xyz^2$
 (B) $x^2y + y^2x + xyz$
 (C) $5xy$
 (D) 0

- Q.4 The first law of thermodynamics can be stated as

- (A) $dE = \delta Q - \delta W$
 (B) $dQ = dE - \delta W$
 (C) $\delta W = dQ + dE$
 (D) $dW = \delta Q - \delta E$

[where, E, Q and W denote internal energy, heat and work, respectively]

- Q.5 In a typical Ellingham diagram for the oxides, the $C + O_2 = CO_2$ line is nearly horizontal because

- (A) The slope of the line is equal to the enthalpy change at standard state, which is approximately zero in this case
 (B) The slope of the line is equal to the entropy change at standard state, which is approximately zero in this case
 (C) CO₂ shows non-ideal behaviour
 (D) CO₂ is a gaseous oxide

- Q.6 Activation energy of a chemical reaction, homogeneous or heterogeneous, is graphically estimated from a plot between
- (A) k versus T (B) $1/k$ versus T
 (C) $1/k$ versus $\ln T$ (D) $\ln k$ versus $1/T$

[where, k is the rate constant and T is the absolute temperature]

- Q.7 The passive film in stainless steel forms above the
- (A) Primary passive potential
 (B) Breakdown potential
 (C) Trans-passive potential
 (D) Pitting potential
- Q.8 During the roasting of a sulfide ore of a metal M , the possible solid phases are M , MS , MO and MSO_4 . Assuming that both SO_2 and O_2 are always present in the roaster, the solid phases that can co-exist at thermodynamic equilibrium are
- (A) M , MS , MO , MSO_4
 (B) M , MO , MSO_4
 (C) MS , MO , MSO_4
 (D) M , MSO_4
- Q.9 Match the entities in **Column I** with the corresponding processes in **Column II**.

Column I

- [P] Xanthate salts
 [Q] Thiobacillus Ferrooxidans
 [R] Hydrocyclone
 [S] Anode effect

Column II

- [1] Extraction of Al
 [2] Flotation
 [3] Classification
 [4] Bacterial Leaching

- (A) P-4, Q-2, R-3, S-1
 (B) P-2, Q-4, R-3, S-1
 (C) P-3, Q-4, R-1, S-2
 (D) P-4, Q-1, R-2, S-3
- Q.10 A substance is used to monitor composition and temperature in
- (A) BOF (B) Ladle refining furnace
 (C) Continuous casting mould (D) Blast furnace
- Q.11 The chemical formula of **wüstite** is
- (A) FeS_2
 (B) Fe_2O_3
 (C) Fe_3O_4
 (D) $Fe_{1-x}O$
- Q.12 The lattice parameter of face-centered cubic iron (γ -Fe) is 0.3571 nm. The radius (in nm) of the octahedral void in γ -Fe is _____

- Q.13 For an ideal hexagonal-closed packed structure, the c/a ratio and packing efficiency respectively are
- (A) 1.633 and 52% (B) 1.633 and 74%
 (C) 1.733 and 68% (D) 1.733 and 74%
- Q.14 A schematic of X-ray diffraction pattern of a single phase cubic polycrystal is given below. The miller indices of **peak A** is

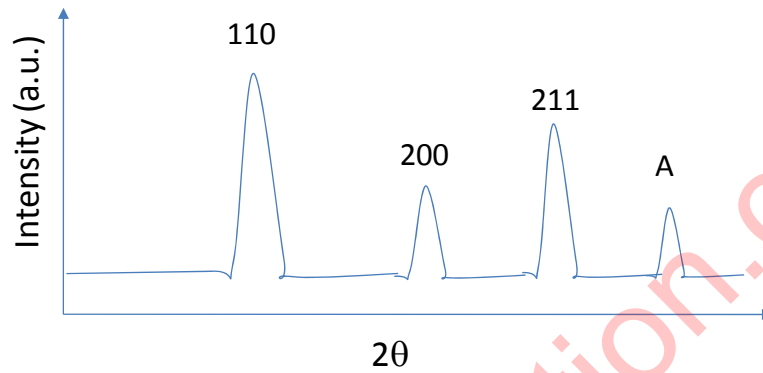

- (A) 210 (B) 220
 (C) 222 (D) 310
- Q.15 Which of the following cooling curves (shown in schematic) in an eutectoid steel will produce 50% bainitic structure?

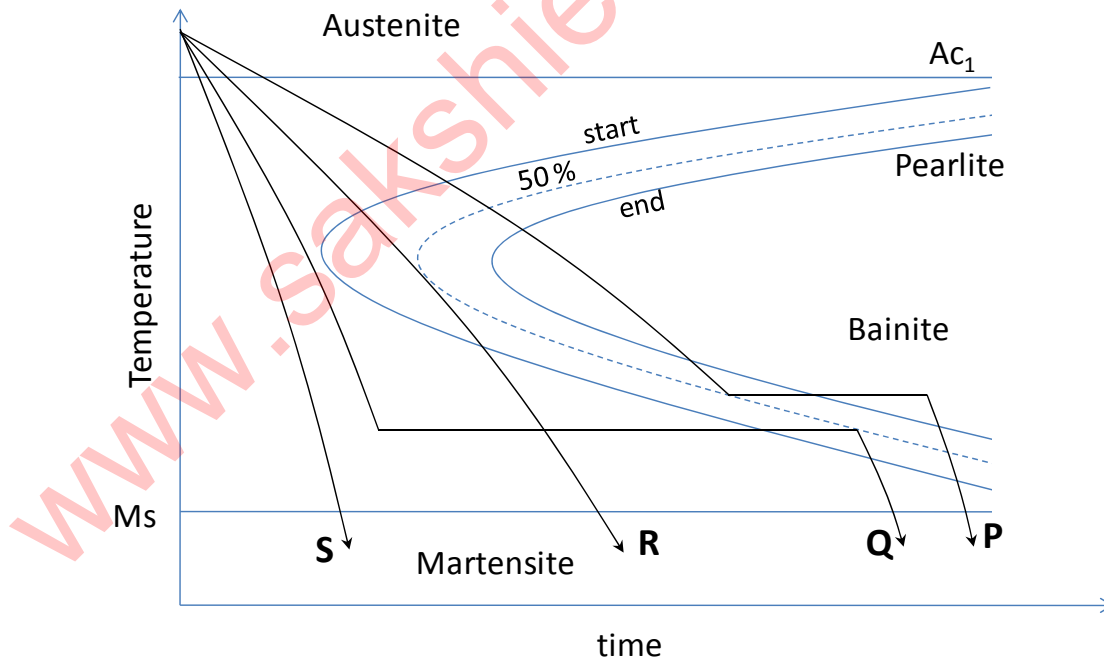

- (A) P (B) Q (C) R (D) S

- Q.16 The Burger's vector of a dislocation in a cubic crystal (with lattice parameter a) is $\frac{a}{2}[110]$ and dislocation line is along $[112]$ direction. The angle (in degrees) between the dislocation line and its Burger's vector is _____
- Q.17 For the tensile stress-strain curve of a material shown in the schematic, the resilience (in MPa) is _____

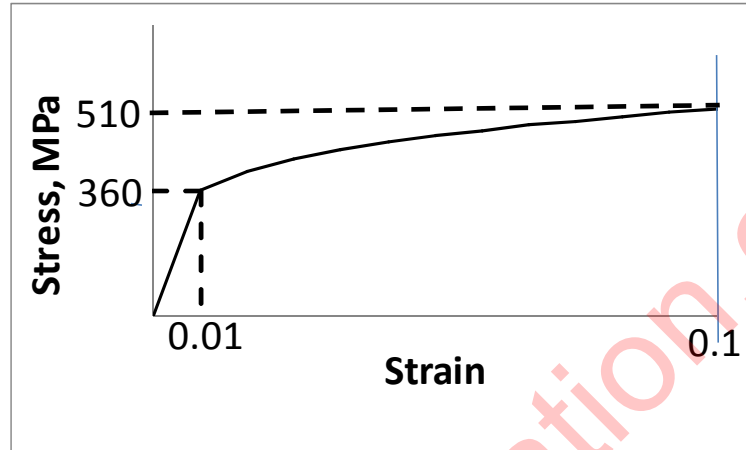

- Q.18 A plastically deformed metal crystal at low temperature exhibits wavy slip line pattern due to
- Dislocation pile-up
 - Large number of slip systems
 - Low stacking fault energy
 - Dislocation climb
- Q.19 Creep resistance decreases due to
- Small grain size
 - Fine dispersoid size
 - Low stacking fault energy
 - High melting point
- Q.20 The operation **NOT** associated with casting is
- | | |
|--------------------|-----------------|
| (A) Gating | (B) Fettling |
| (C) Stack Moulding | (D) Calendaring |

Q.21 Of the following welding processes

- [P] Laser Beam Welding
[Q] Submerged Arc Welding
[R] Metal Inert Gas Welding

the width of the heat-affected zone in decreasing order is

- (A) $P > Q > R$ (B) $Q > R > P$
(C) $R > P > Q$ (D) $P > R > Q$

Q.22 Railway tracks are typically manufactured using

- (A) Forging (B) Extrusion
(C) Deep Drawing (D) Rolling

Q.23 For dye-penetrant test, identify the **CORRECT** statement

- (A) Pre- and post-cleaning of parts are not required
(B) Internal defects can be detected
(C) Surface oxides helps in crack identification
(D) Dye with low contact angle is required

Q.24 Aluminium powder having an apparent density of 810 kg.m^{-3} is compacted in a cylindrical die at 600 MPa. The density of the as-pressed aluminium compact is 1755 kg.m^{-3} . If the height of the as-pressed compact is 12 mm, the fill height (in mm) required is _____

Q.25 A rolling mill has a roll diameter of 200 mm. If coefficient of friction is 0.1, then the maximum possible reduction (in mm) during rolling of a 250 mm thick plate is _____

Q. 26 – Q. 55 carry two marks each.

Q.26 A hot body cools according to the following equation

$$\frac{dT}{dt} = -cT$$

where, T is the instantaneous temperature at time t, and the constant $c = 0.05 \text{ s}^{-1}$. Reduce the differential equation into its finite difference form **using forward difference**. For maintaining numerical stability, the maximum value of the time step Δt (in seconds) is _____

Q.27 Solve the equation $x = e^{-x}$ using Newton-Raphson method. Starting with an initial guess value $x_0 = 0$, the value of x after the first iteration is _____

Q.28 A coin is tossed three times. It is known that out of the three tosses, one is a **HEAD**. The probability of the other two tosses also being **HEADS** is _____

Q.29 The vector parallel to the plane $3x - 2y + z = -1$ is

- (A) $\hat{i} + \hat{j} - \hat{k}$
 (B) $3\hat{i} - 2\hat{j} + \hat{k}$
 (C) $-\hat{i} + \hat{j} - \hat{k}$
 (D) $3\hat{i} - 2\hat{j} + 2\hat{k}$

Q.30 The value of the integral

$$\int_0^{\pi/2} x \sin x \, dx = \underline{\hspace{2cm}}$$

Q.31 The grain sizes (in μm) measured at five locations in an alloy sample are: 16, 14, 18, 15 and 13. The mean, median and standard deviation of grain sizes respectively are (in μm)

- (A) 15.2, 15 and 1.7
 (B) 15.2, 15 and 1.9
 (C) 15.8, 15 and 1.9
 (D) 15.2, 16 and 1.7

Q.32 The change of standard state from pure liquid to 1 wt.% for Si dissolved in liquid Fe at 1873 K is expressed as

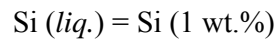

Given that the activity coefficient of Si at infinite dilution in Fe is 10^{-3} , the standard Gibbs free energy change (in kJ) for this equilibrium is _____

Q.33 The following experimental data are available for a hypothetical binary liquid system **A-B** at 1073 K

Atom fraction of A	0.2	0.4	0.5	0.7	1.0
Partial pressure of A (bar)	0.01	0.04	0.06	0.07	0.08

When the atom fraction of A is 0.4, the activity of A in the liquid is _____

- Q.34 The lining of a box-type furnace is made up of a refractory layer and steel plate as shown in the figure. Steady state temperature at the surface of the refractory is 1273 K and that at the outer steel surface is 473 K. If the steady-state heat flux through the refractory-steel plate composite is 1600 W.m^{-2} , and heat flow is along x-direction, the thermal contact resistance ($\text{W}^{-1}.\text{m}^2.\text{K}$) between refractory and steel is _____

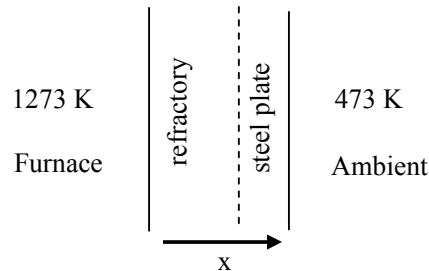

Given data:

Thermal conductivity of refractory	= $1.2 \text{ W.m}^{-1}\text{K}^{-1}$
Thickness of refractory lining	= 80 mm
Thermal conductivity of steel	= $32 \text{ W.m}^{-1}\text{K}^{-1}$
Thickness of steel plate	= 4 mm

- Q.35 The height of a liquid metal column in a cylindrical vessel is 3.2 m. At time $t=0$, liquid metal is drained out from the vessel through a small nozzle located at the base of the vessel. Neglecting frictional losses, the initial mass flow rate (in kg.s^{-1}) through the nozzle is _____

Given data:

Density of liquid metal	= 7000 kg.m^{-3}
Nozzle diameter	= 30 mm
Nozzle discharge coefficient	= 0.80

- Q.36 Match entities listed in **Column I** with their correct dimensions given in **Column II**:

Column I

- [P] Drag coefficient
 [Q] Mass transfer coefficient
 [R] Viscosity
 [S] Mass flux

Column II

- [1] $\text{ML}^{-1}\text{T}^{-1}$
 [2] $\text{ML}^{-2}\text{T}^{-1}$
 [3] $\text{M}^0\text{L}^0\text{T}^0$
 [4] M^0LT^{-1}

- (A) P-3, Q-4, R-1, S-2
 (C) P-1, Q-4, R-2, S-3

- (B) P-3, Q-1, R-2, S-4
 (D) P-4, Q-3, R-1, S-2

- Q.37 Direct Reduced Iron (DRI) produced from a gas based process contains Fe, FeO, C and remainder being gangue. The chemical composition of DRI is: *Total Fe* = 92 wt.% and *Metallic Fe* = 84 wt.%. The weight percent of FeO in DRI is _____

- Q.38 Mould heat flux (q_m) for billet casters is expressed (in SI unit) as a function of distance below the meniscus (z)

$$q_m(z) = \left[2.67 - 0.33 \sqrt{\frac{z}{U_c}} \right] \times 10^6 \quad (0 \leq z \leq L_m)$$

If mould length (L_m) is 0.8 m and casting speed (U_c) is 0.2 m.s^{-1} , the average mould flux (in MW.m^{-2}) is _____

- Q.39 In BOF steelmaking, 5 metric ton of lime containing 90 wt.% CaO is used to refine 100 metric ton of hot metal containing 93.2 wt.% Fe. The slag produced during refining contains 40 wt.% CaO and 22 wt.% FeO. Neglecting material losses, the yield of Fe (in %) is _____
- Q.40 In vacuum degassing of steel, 14 ppm of dissolved nitrogen is in equilibrium with 1 mbar of nitrogen gas at 1873 K. At the same temperature, if the pressure is lowered to 0.7 mbar, the equilibrium nitrogen content (in ppm) is _____
- Q.41 During isothermal phase transformation (in solid-state), fraction transformed is measured at two different transformation times:

Transformation Time, t (s)	Fraction Transformed, f
75	0.11
150	0.37

Assuming Avrami kinetics [$f = 1 - \exp(-kt^n)$], the fraction transformed in 300 seconds is _____

- Q.42 Zinc oxide is reduced at a constant temperature in a closed reactor using ZnO(s) and C(s) as the only starting materials. The following reactions are assumed to be at thermodynamic equilibrium:

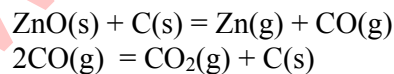

Assume ideal gas behaviour. Based on mole balance, the relationship applicable to the system at equilibrium is

- (A) $p_{\text{Zn}} = p_{\text{CO}} + 2p_{\text{CO}_2}$
 (B) $p_{\text{Zn}} = 2p_{\text{CO}} + p_{\text{CO}_2}$
 (C) $p_{\text{Zn}} = p_{\text{CO}} + p_{\text{CO}_2}$
 (D) $p_{\text{Zn}} = 0.5 p_{\text{CO}} + 2p_{\text{CO}_2}$

Q.43 The critical nucleus size (in nm) when copper melt is under-cooled by 100 K is

Given data:

Melting point:	1356 K
Density:	8900 kg.m^{-3}
Solid-liquid interfacial energy:	0.5 Jm^{-2}
Latent heat of freezing:	13000 J.mol^{-1}
Molar volume:	$7 \times 10^{-6} \text{ m}^{-3} \text{ mol}^{-1}$

- (A) 0.36 (B) 1.55 (C) 3.65 (D) 7.30

Q.44 The density and corresponding crystallinity of two poly-propylene material are given below

Density, kg.m^{-3}	Crystallinity, %
904	62.8
895	54.4

The density of totally amorphous poly-propylene (in kg.m^{-3}) is:

- (A) 723 (B) 841 (C) 905 (D) 956

Q.45 A simplified energy band-diagram of an intrinsic semiconductor at thermal equilibrium (300 K) is shown. In the accompanying table, which one of the four columns correctly represents the listed parameters? Assume same effective mass for electrons and holes.

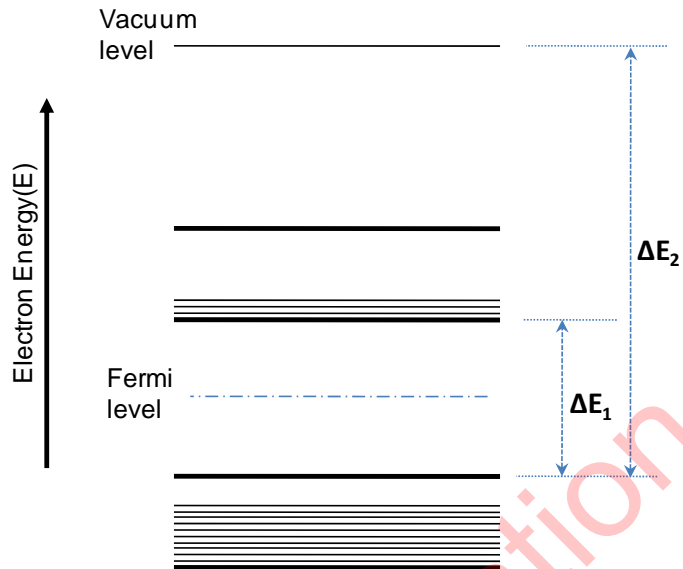

Parameter	Energy-difference			
	Column 1	Column 2	Column 3	Column 4
Band-gap	ΔE_2	ΔE_1	ΔE_2	ΔE_1
Electron affinity	$\Delta E_1/2$	$\Delta E_2 - \Delta E_1$	$\Delta E_2/2$	$\Delta E_2 - (\Delta E_1/2)$
Work function	$\Delta E_1 + \Delta E_2$	$\Delta E_2 - (\Delta E_1/2)$	$\Delta E_1 - \Delta E_2/2$	$\Delta E_2 + (\Delta E_1/2)$

- (A) Column 1 (B) Column 2 (C) Column 3 (D) Column 4

Q.46 A binary phase diagram is shown in the schematic.

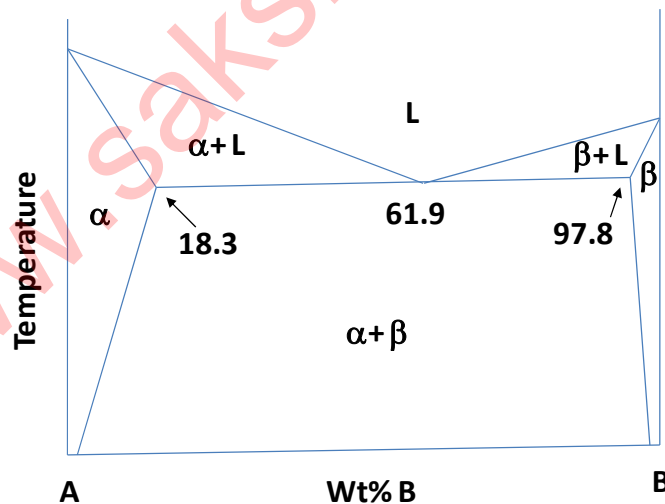

Upon complete solidification of a binary alloy system A-B, the fraction of pro-eutectic α -phase present is 0.50. The alloy composition in terms of wt%. B is _____

- Q.47 Fatigue behaviour of an aluminium alloy is shown in the S-N plot. A piston rod made of this material is subjected to: (i) 1000 cycles at 420 MPa, followed by (ii) 1000 cycles at 300 MPa. Using Miner's rule of cumulative damage, the remaining fatigue life (in terms of number of cycles) at stress of 250 MPa is _____

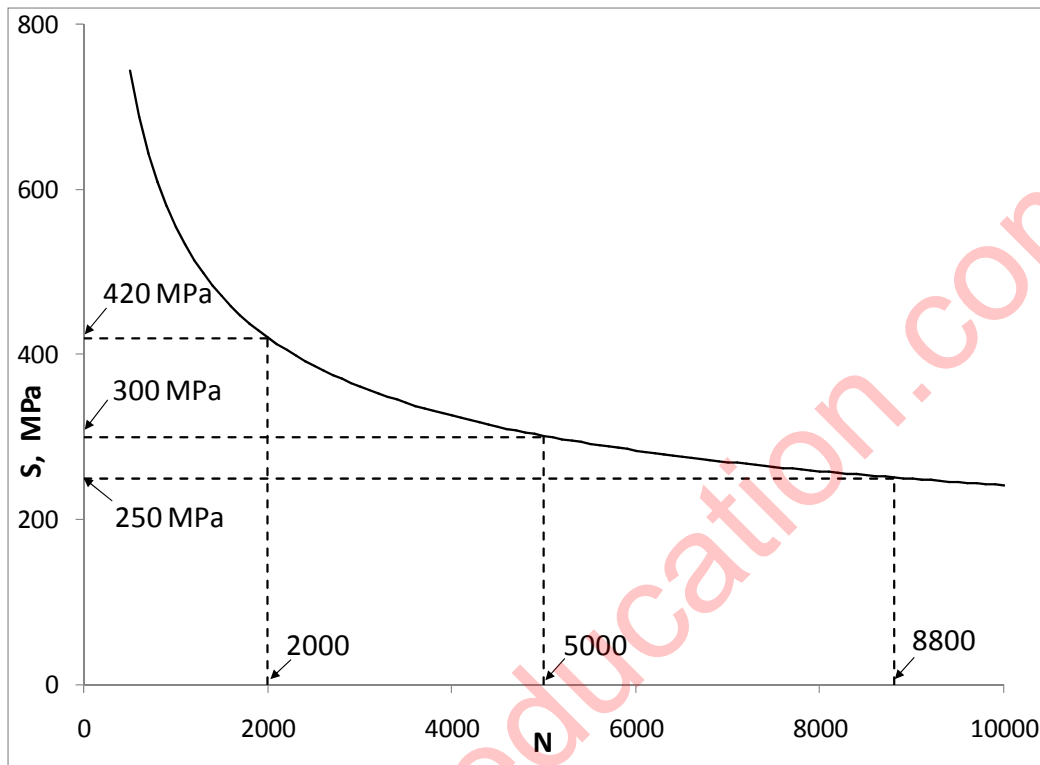

- Q.48 A glass plate has two parallel cracks. One of them is an internal crack of length $5 \mu\text{m}$ and the other is a surface crack of length $3 \mu\text{m}$. A tensile stress is applied perpendicular to the crack surfaces. The fracture stress (in MPa) is _____

Given data (for glass plate):

$$\begin{aligned} \text{Young's Modulus} &= 70 \text{ GPa} \\ \text{Surface energy per unit area} &= 1 \text{ J.m}^{-2} \end{aligned}$$

- Q.49 A tensile stress is applied along the [100] direction in a FCC metal crystal. The critical resolved shear stress is 6 MPa. The tensile stress (in MPa) required for initiating slip on the (111) slip plane is _____

- Q.50 For a bcc metal the ratio of the surface energy per unit area of the (100) plane to that of the (110) plane is _____

- Q.51 For a polymer reinforced with 40 vol.% glass fiber, the elastic modulus (in GPa) along the transverse direction is

- (A) 5.6 (B) 8.1
(C) 30.1 (D) 43.4

$$[E_{\text{glass fiber}} = 70 \text{ GPa}; E_{\text{polymer}} = 3.5 \text{ GPa}]$$

Q.52 In a sand-mould, a sprue of 0.25 m height and a top cross-section area of 2.2 m^2 is provided to maintain the melt flow rate at $4 \text{ m}^3 \cdot \text{s}^{-1}$. To prevent aspiration of molten metal, the maximum cross-section area (in m^2) at the base of the sprue is _____

Q.53 For casting a cylindrical aluminum bloom having a length of 1000 mm and diameter of 750 mm, the approximate solidification time (in minutes) estimated using Chvorinov's rule is

- (A) 45 (B) 316 (C) 440 (D) 620

[The mould constant is 2 s/mm^2]

Q.54 A liquid phase sintered SiC-Ni composite has a solid-solid grain boundary energy ($\gamma_{\text{SiC-SiC}}$) of 0.80 J.m^{-2} and a solid-liquid ($\gamma_{\text{SiC-Ni}}$) interfacial energy of 0.45 J.m^{-2} . For a SiC grain size of $20 \mu\text{m}$, the average interparticle (SiC-SiC) neck size (in μm) is:

- (A) 3.03 (B) 4.28 (C) 9.16 (D) 18.32

Q.55 Match the deformation processes in **Column I** with the corresponding stress states listed in **Column II**

Column I

- [P] Wire Drawing
[Q] Forging
[R] Stretch Forming
[S] Cutting

Column II

- [1] Direct Compression
[2] Indirect Compression
[3] Tension
[4] Shear

(A) P-1; Q-2; R-3; S-4

(B) P-1; Q-2; R-4; S-3

(C) P-2; Q-1; R-3; S-4

(D) P-2; Q-1; R-4; S-3

END OF THE QUESTION PAPER

Q. No	Type	Section	Key	Marks
1	MCQ	GA	C	1
2	MCQ	GA	A	1
3	MCQ	GA	C	1
4	MCQ	GA	A	1
5	MCQ	GA	A	1
6	MCQ	GA	D	2
7	MCQ	GA	D	2
8	MCQ	GA	B	2
9	MCQ	GA	D	2
10	MCQ	GA	C	2
1	NAT	MT	0.99 : 1.01	1
2	MCQ	MT	D	1
3	MCQ	MT	C	1
4	MCQ	MT	A	1
5	MCQ	MT	B	1
6	MCQ	MT	D	1
7	MCQ	MT	A	1
8	MCQ	MT	C	1
9	MCQ	MT	B	1
10	MCQ	MT	A	1
11	MCQ	MT	D	1
12	NAT	MT	0.045 : 0.06	1
13	MCQ	MT	B	1
14	MCQ	MT	B	1
15	MCQ	MT	B	1
16	NAT	MT	54.0 : 55.5	1
17	NAT	MT	1.7 : 1.9	1
18	MCQ	MT	B	1
19	MCQ	MT	A	1
20	MCQ	MT	D	1
21	MCQ	MT	B	1
22	MCQ	MT	D	1
23	MCQ	MT	D	1
24	NAT	MT	25.5 : 26.5	1
25	NAT	MT	0.9 : 1.1	1
26	NAT	MT	19.9 : 20.1	2
27	NAT	MT	0.49 : 0.51	2
28	NAT	MT	0.135 : 0.150	2
29	MCQ	MT	A	2
30	NAT	MT	0.99 : 1.01	2
31	MCQ	MT	B	2
32	NAT	MT	-168.7 : -168.1	2
33	NAT	MT	0.499 : 0.501	2
34	NAT	MT	0.42 : 0.44	2
35	NAT	MT	31.0 : 32.0	2
36	MCQ	MT	A	2
37	NAT	MT	10.0 : 10.5	2
38	NAT	MT	2.0 : 2.5	2
39	NAT	MT	97.5 : 98.3	2

40	NAT	MT	11.6 : 11.8	2
41	NAT	MT	0.81 : 0.87	2
42	MCQ	MT	A	2
43	MCQ	MT	MTA	2
44	MCQ	MT	B	2
45	MCQ	MT	B	2
46	NAT	MT	40.0 : 40.2	2
47	NAT	MT	2630 : 2650	2
48	NAT	MT	115 : 125	2
49	NAT	MT	14.0 : 15.5	2
50	NAT	MT	1.3 : 1.5	2
51	MCQ	MT	A	2
52	NAT	MT	1.7 : 1.9	2
53	MCQ	MT	D	2
54	MCQ	MT	C	2
55	MCQ	MT	C	2

www.sakshieducation.com