

# CHAPTER

# 10

# Mensuration

## 10.1 INTRODUCTION

In classes VIII and IX, we have learnt about area, surface area and volume of solid shapes. We did many exercises to understand what they mean. We used them in real life situations and identified what we needed and what was to be measured or estimated. For example, to find the quantity of paint required to white wash a room, we need the surface area and not the volume. To find the number of boxes that would contain a quantity of grain, we need the volume and not the area.



### TRY THIS

1. Consider the following situations. In each find out whether you need volume or area and why?
  - i. Quantity of water inside a bottle.
  - ii. Canvas needed for making a tent.
  - iii. Number of bags inside the lorry.
  - iv. Gas filled in a cylinder.
  - v. Number of match sticks that can be put in the match box.
2. Compute 5 more such examples and ask your friends to choose what they need?

We see so many things of different shapes (combination of two or more) around us. Houses stand on pillars, storage water tanks are cylindrical and are placed on cuboidal foundations, a cricket bat has a cylindrical handle and a flat main body, etc. Think of different things around you. Some of these are shown below:

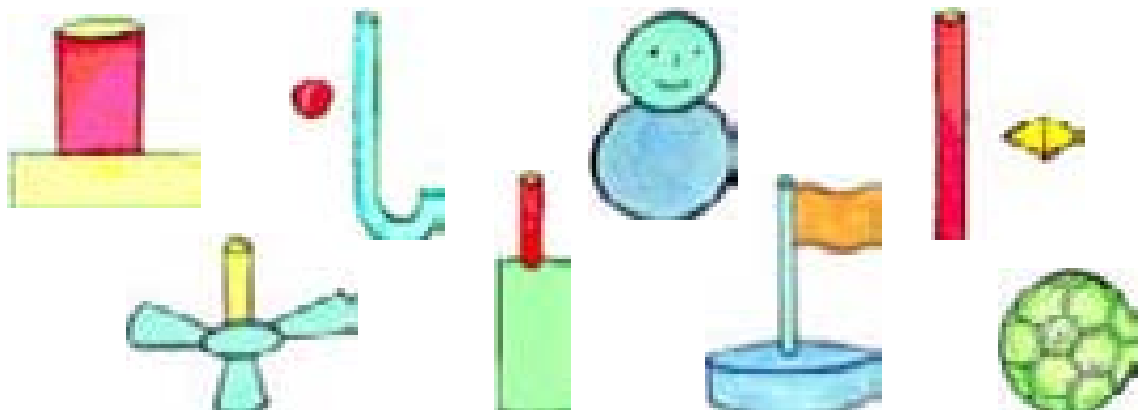





Of these objects like football have shapes where we know that the surface area and volume. We can however see that other objects can be seen as combinations of the solid shapes. So, their surface area and volume we now have to find. The table of the solid shapes, their areas and volumes are given later.

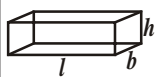
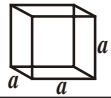

### TRY THIS

1. Break the pictures in the previous figure into solids of known shapes.
2. Think of 5 more things around you that can be seen as a combination of shapes. Name the shapes that combine to make them.

Let us recall the surface areas and volumes of different solid shapes.

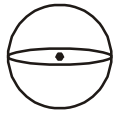
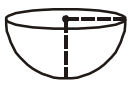
S. No.	Name of the solid	Figure	Lateral / Curved surface area	Total surface area	Volume	Nomenclature
1.	Cuboid		$2h(l+b)$	$2(lb+bh+hl)$	$lbh$	$l$ :length $b$ :breadth $h$ :height
2.	Cube		$4a^2$	$6a^2$	$a^3$	$a$ :side of the cube
3.	Right prism		Perimeter of base $\times$ height	Lateral surface area+2(area of the end surface)	area of base $\times$ height	-
4.	Regular circular Cylinder		$2\pi rh$	$2\pi r(r+h)$	$\pi r^2 h$	$r$ :radius of the base $h$ :height
5.	Right pyramid		$\frac{1}{2}$ (perimeter of base) $\times$ slant height	Lateral surfaces area+area of the base	$\frac{1}{3}$ area of the base $\times$ height	-
6.	Right circular cone		$\pi rl$	$\pi r(l+r)$	$\frac{1}{3} \pi r^2 h$	$r$ :radius of the base $h$ :height $l$ :slant height
7.	Sphere		$4\pi r^2$	$4\pi r^2$	$\frac{4}{3} \pi r^3$	$r$ :radius
8.	Hemisphere		$2\pi r^2$	$3\pi r^2$	$\frac{2}{3} \pi r^3$	$r$ :radius

Now, let us see some examples to illustrate the shapes in the table.

**Example-1.** The radius of a conical tent is 7 meters and its height is 10 meters. Calculate the length of canvas used in making the tent if width of canvas is 2m.  $\left[ \text{Use } \pi = \frac{22}{7} \right]$

**Solution :** If the radius of conical tent is given ( $r$ ) = 7 metres

$$\text{Height}(h) = 10 \text{ m.}$$

$$\begin{aligned} \therefore \text{ So, the slant height of the cone } l^2 &= r^2 + h^2 \Rightarrow l = \sqrt{r^2 + h^2} \\ &= \sqrt{49 + 100} \\ &= \sqrt{149} = 12.2 \text{ m.} \end{aligned}$$

Now, Surface area of the tent =  $\pi r l$

$$\begin{aligned} &= \frac{22}{7} \times 7 \times 12.2 \text{ m}^2 \\ &= 268.4 \text{ m}^2. \end{aligned}$$

Area of canvas used =  $268.4 \text{ m}^2$

It is given the width of the canvas = 2m

$$\text{Length of canvas used} = \frac{\text{Area}}{\text{width}} = \frac{268.4}{2} = 134.2 \text{ m}$$

**Example-2.** An oil drum is in the shape of a cylinder having the following dimensions: diameter is 2 m. and height is 7 meters. The painter charges ₹3 per  $\text{m}^2$  to paint the drum. Find the total charges to be paid to the painter for 10 drums ?

**Solution :** It is given that diameter of the (oil drum) cylinder = 2 m.

$$\text{Radius of cylinder} = \frac{d}{2} = \frac{2}{2} = 1 \text{ m}$$

Total surface area of a cylindrical drum =  $2 \times \pi r(r + h)$

$$\begin{aligned} &= 2 \times \frac{22}{7} \times 1(1 + 7) \\ &= 2 \times \frac{22}{7} \times 8 \end{aligned}$$

$$= \frac{352}{7} m^2 = 50.28 m^2$$

So, the total surface area of a drum =  $50.28 m^2$

Painting charge per  $1m^2$  = ₹3.

Cost of painting of 10 drums =  $50.28 \times 3 \times 10$   
= ₹1508.40

**Example-3.** A sphere, a cylinder and a cone are of the same radius and same height. Find the ratio of their curved surface areas?

**Solution :** Let  $r$  be the common radius of a sphere, a cone and cylinder.

Height of sphere = its diameter =  $2r$ .

Then, the height of the cone = height of cylinder = height of sphere.  
=  $2r$ .

Let  $l$  be the slant height of cone =  $\sqrt{r^2 + h^2}$

$$= \sqrt{r^2 + (2r)^2} = \sqrt{5}r$$

$\therefore S_1$  = Curved surface area of sphere =  $4\pi r^2$

$S_2$  = Curved surface area of cylinder,  $2\pi rh = 2\pi r \times 2r = 4\pi r^2$

$S_3$  = Curved surface area of cone =  $\pi rl = \pi r \times \sqrt{5}r = \sqrt{5}\pi r^2$

Ratio of curved surface area as

$$\begin{aligned} \therefore S_1 : S_2 : S_3 &= 4\pi r^2 : 4\pi r^2 : \sqrt{5}\pi r^2 \\ &= 4 : 4 : \sqrt{5} \end{aligned}$$

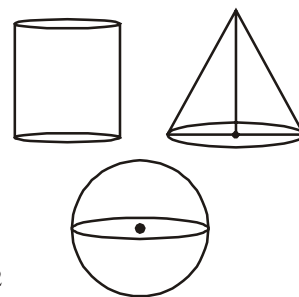

**Example-4.** A company wanted to manufacture 1000 hemispherical basins from a thin steel sheet. If the radius of hemispherical basin is  $21\text{ cm}$ ., find the required area of steel sheet to manufacture the above hemispherical basins?

**Solution :** Radius of the hemispherical basin ( $r$ ) =  $21\text{ cm}$

Surface area of a hemispherical basin

$$\begin{aligned} &= 2\pi r^2 \\ &= 2 \times \frac{22}{7} \times 21 \times 21 \\ &= 2772\text{ cm}^2. \end{aligned}$$

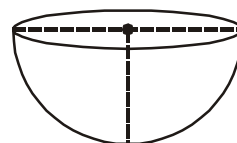

So, surface area of a hemispherical basin  
 $= 2772 \text{ cm}^2$ .

Hence, the steel sheet required for one basin  $= 2772 \text{ cm}^2$

Total area of steel sheet required for 1000 basins  $= 2772 \times 1000$   
 $= 2772000 \text{ cm}^2$   
 $= 277.2 \text{ m}^2$

**Example-5.** A right circular cylinder has base radius 14cm and height 21cm.

Find: (i) Area of base or area of each end (ii) Curved surface area  
 (iii) Total surface area and (iv) Volume of the right circular cylinder.

**Solution :** Radius of the cylinder (r) = 14cm  
 Height of the cylinder (h) = 21cm

Now (i) Area of base(area of each end)  $\pi r^2 = \frac{22}{7} (14)^2 = 616 \text{ cm}^2$

(ii) Curved surface area  $= 2\pi rh = 2 \times \frac{22}{7} \times 14 \times 21 = 1848 \text{ cm}^2$ .

(iii) Total surface area  $= 2 \times \text{area of the base} + \text{curved surface area}$   
 $= 2 \times 616 + 1848 = 3080 \text{ cm}^2$ .

(iv) Volume of cylinder  $= \pi r^2 h = \text{area of the base} \times \text{height}$   
 $= 616 \times 21 = 12936 \text{ cm}^3$ .

**Example-6.** Find the volume and surface area of a sphere of radius 2.1 cm ( $\pi = \frac{22}{7}$ )

**Solution :** Radius of sphere (r) = 2.1 cm

Surface area of sphere  $= 4\pi r^2$   
 $= 4 \times \frac{22}{7} \times (2.1)^2 = 4 \times \frac{22}{7} \times \frac{21}{10} \times \frac{21}{10}$   
 $= \frac{1386}{25} = 55.44 \text{ cm}^2$

Volume of sphere  $= \frac{4}{3} \pi r^3 = \frac{4}{3} \times \frac{22}{7} \times (2.1)^3$

$$= \frac{4}{3} \times \frac{22}{7} \times 2.1 \times 2.1 \times 2.1 = 38.808 \text{ cm}^3.$$

**Example-7.** Find the volume and the total surface area of a hemisphere of radius 3.5 cm.

$$\left( \pi = \frac{22}{7} \right)$$

**Solution :** Radius of sphere ( $r$ ) is 3.5 cm =  $\frac{7}{2}$  cm

$$\text{Volume of hemisphere} = \frac{2}{3} \pi r^3$$

$$= \frac{2}{3} \times \frac{22}{7} \times \frac{7}{2} \times \frac{7}{2} \times \frac{7}{2} = \frac{539}{6} = 89.83 \text{ cm}^3$$

$$\text{Total surface area} = 3\pi r^2$$

$$= 3 \times \frac{22}{7} \times \frac{7}{2} \times \frac{7}{2} = \frac{231}{2} = 115.5 \text{ cm}^2$$



### EXERCISE - 10.1

1. A joker's cap is in the form of right circular cone whose base radius is 7cm and height is 24 cm. Find the area of the sheet required to make 10 such caps.
2. A sports company was ordered to prepare 100 paper cylinders for shuttle cocks. The required dimensions of the cylinder are 35 cm length /height and its radius is 7 cm. Find the required area of thin paper sheet needed to make 100 cylinders?
3. Find the volume of right circular cone with radius 6 cm. and height 7cm.
4. The lateral surface area of a cylinder is equal to the curved surface area of a cone. If the radius be the same, find the ratio of the height of the cylinder and slant height of the cone.
5. A self help group wants to manufacture joker's caps (conical caps) of 3cm. radius and 4 cm. height. If the available colour paper sheet is  $1000 \text{ cm}^2$ , then how many caps can be manufactured from that paper sheet?
6. A cylinder and cone have bases of equal radii and are of equal heights. Show that their volumes are in the ratio of 3:1.
7. A solid iron rod has a cylindrical shape. Its height is 11 cm. and base diameter is 7cm. Then find the total volume of 50 rods?

8. A heap of rice is in the form of a cone of diameter  $12\text{ m}$ . and height  $8\text{ m}$ . Find its volume? How much canvas cloth is required to cover the heap ? (Use  $\pi = 3.14$ )
9. The curved surface area of a cone is  $4070\text{ cm}^2$  and its diameter is  $70\text{ cm}$ . What is its slant height?

## 10.2 SURFACE AREA OF THE COMBINATION OF SOLIDS

We have seen solids which are made up of combination of solids known like sphere cylinder and cone. We can observe in our real life also like wooden things, house items, medicine capsules, bottles, oil-tankers etc., We eat ice-cream in our daily life. Can you tell how many solid figures are there in it? It is usually made up of cone and hemisphere.



Lets take another example of an oil-tanker/ water-tanker. Is it a single shaped object? You may guess that it is made up of a cylinder with two hemisphere at it ends.

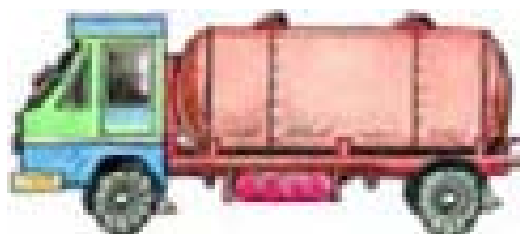

If, for some reason you wanted to find the surface areas or volumes or capacities of such objects, how would you do it? We cannot classify these shapes under any of the solids you have already studied.

As we have seen, the oil-tanker was made up of a cylinder with two hemispheres stuck at either end. It will look like the following figure:

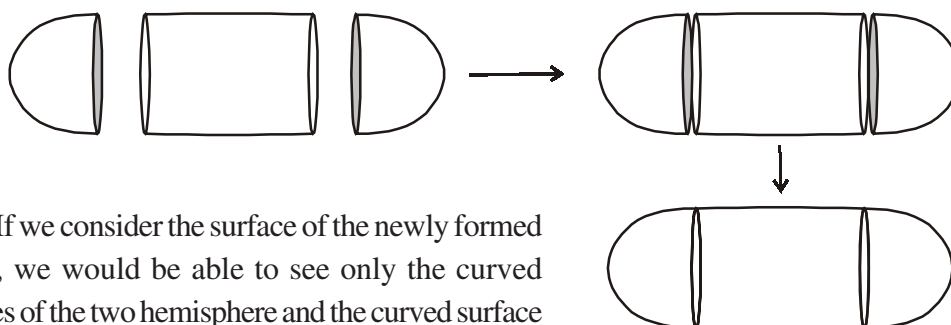

If we consider the surface of the newly formed object, we would be able to see only the curved surfaces of the two hemisphere and the curved surface of the cylinder.

TSA of new solid = CSA of one hemisphere + CSA of cylinder + CSA of other hemisphere

here TSA and CSA stand for 'total surface area' and 'curved surface area' respectively. Now look at another example.

Devarsha wants to make a toy by putting together a hemisphere and a cone. Let us see the steps that he should be going through.

First, he should take a cone and hemisphere and bring their flat faces together. Here, of course, he should take the base radius of the cone equal to the radius of the hemisphere, for the toy is to have a smooth surface. So, the steps would be as shown below:

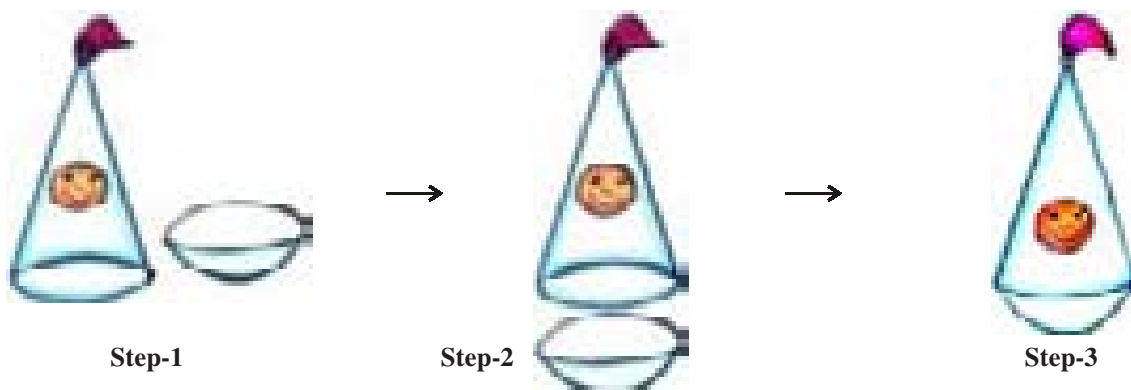

At the end, he got a nice round-bottomed toy. Now, if he wants to find how much paint he should be required to colour the surface of the toy, what should he know? He needs to know the surface area of the toy, which consists of the CSA of the hemisphere and the CSA of the cone.

So, we can say that

TSA of the toy = CSA of Hemisphere + CSA of cone



### TRY THIS

- Use known solid shapes and make as many objects (by combining more than two) as possible that you come across in your daily life.

[Hint : Use clay, or balls, pipes, paper cones, boxes like cube, cuboid etc]



### THINK - DISCUSS

A sphere is inscribed in a cylinder. Is the surface of the sphere equal to the curved surface of the cylinder? If yes, explain how?

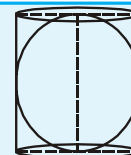

**Example-8.** A right triangle, whose base and height are 15 cm. and 20 cm. respectively is made to revolve about its hypotenuse. Find the volume and surface area of the double cone so formed (Use  $\pi=3.14$ ).

**Solution :** Let ABC be the right angled triangle such that

$$AB = 15\text{cm and } AC = 20\text{ cm}$$

Using Pythagoras theorem in  $\Delta ABC$  we have

$$BC^2 = AB^2 + AC^2$$



$$BC^2 = 15^2 + 20^2$$

$$BC^2 = 225 + 400 = 625$$

$$BC = \sqrt{625} = 25 \text{ cm.}$$

Let  $OA = x$  and  $OB = y$ .

In triangles  $ABO$  and  $ABC$ , we have  $\angle BOA = \angle BAC$  and  $\angle ABO = \angle ABC$

So, by angle - angle - criterion of similarity, we have  $\Delta BOA \sim \Delta BAC$

Therefore,  $\frac{BO}{BA} = \frac{OA}{AC} = \frac{BA}{BC}$

$$\Rightarrow \frac{y}{15} = \frac{x}{20} = \frac{15}{25}$$

$$\Rightarrow \frac{y}{15} = \frac{x}{20} = \frac{3}{5}$$

$$\Rightarrow \frac{y}{15} = \frac{3}{5} \text{ and } \frac{x}{20} = \frac{3}{5}$$

$$\Rightarrow y = \frac{3}{5} \times 15 \text{ and } x = \frac{3}{5} \times 20$$

$$\Rightarrow y = 9 \text{ and } x = 12.$$

Thus, we have

$$OA = 12 \text{ cm and } OB = 9 \text{ cm}$$

When the  $ABC$  is revolved about the hypotenuse, we get a double cone as shown in figure.

Volume of the double cone = volume of the cone  $CAA'$  + volume of the cone  $BAA'$

$$= \frac{1}{3} \pi(OA)^2 \times OC + \frac{1}{3} \pi(OA)^2 \times OB$$

$$= \frac{1}{3} \pi \times 12^2 \times 16 + \frac{1}{3} \pi \times 12^2 \times 9$$

$$= \frac{1}{3} \pi \times 144(16+9)$$

$$= \frac{1}{3} \times 3.14 \times 144 \times 25 \text{ cm}^3$$

$$= 3768 \text{ cm}^3.$$

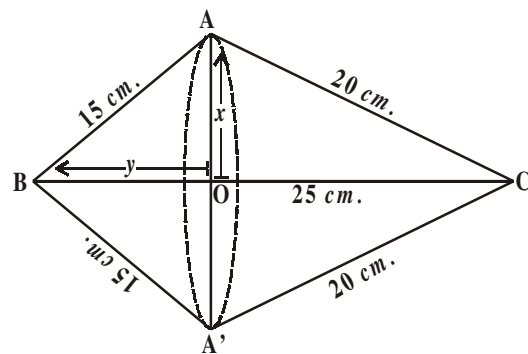

$$\begin{aligned}
 \text{Surface area of the doubled cone} &= (\text{Curved surface area of cone CAA}') \\
 &\quad + (\text{Curved surface area of cone BAA}') \\
 &= (\pi \times OA \times AC) + (\pi \times OA \times AB) \\
 &= (\pi \times 12 \times 20) + (\pi \times 12 \times 15) \text{ cm}^2 \\
 &= 420 \pi \text{ cm}^2 \\
 &= 420 \times 3.14 \text{ cm}^2 \\
 &= 1318.8 \text{ cm}^2.
 \end{aligned}$$

**Example-9.** A wooden toy rocket is in the shape of a cone mounted on a cylinder as shown in the adjacent figure. The height of the entire rocket is 26 cm, while the height of the conical part is 6 cm. The base of the conical portion has a diameter of 5 cm, while the base diameter of the cylindrical portion is 3 cm. If the conical portion is to be painted orange and the cylindrical portion is to be painted yellow, find the area of the rocket painted with each of these color (Take  $\pi = 3.14$ )

**Solution :** Let 'r' be the radius of the base of the cone and its slant height be 'l'. Further, let  $r_1$  be the radius of cylinder and  $h_1$  be its height

We have,

$$r = 2.5 \text{ cm.}, \quad h = 6 \text{ cm.}$$

$$r_1 = 1.5 \text{ cm.} \quad h_1 = 20 \text{ cm.}$$

$$\text{Now, } l = \sqrt{r^2 + h^2}$$

$$\Rightarrow l = \sqrt{(2.5)^2 + 6^2}$$

$$l = \sqrt{6.25 + 36} = \sqrt{42.25} = 6.5$$

Now, area to be painted orange

= Curved surface area of the cone

$$= \pi r l$$

$$= 3.14 \{2.5 \times 6.5\}$$

$$= 51.025 \text{ cm}^2$$

Area to be painted yellow

= Curved surface area of the cylinder + Area of the base of the cylinder

$$= 2\pi r_1 h_1 + \pi r_1^2$$

$$= \pi r_1 (2h_1 + r_1)$$

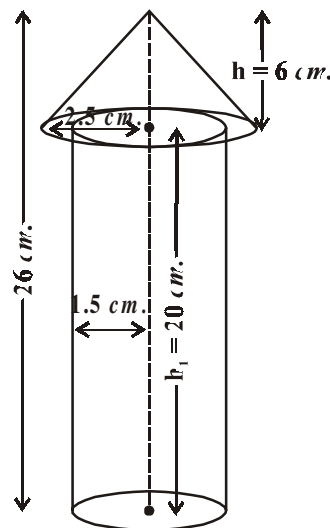

$$\begin{aligned}
 &= 3.14 \times 1.5 (2 \times 20 + 1.5) \text{ cm}^2 \\
 &= 3.14 \times 1.5 \times 41.5 \text{ cm}^2 \\
 &= 4.71 \times 41.5 \text{ cm}^2 \\
 &= 195.465 \text{ cm}^2.
 \end{aligned}$$

Therefore, area to be painted yellow =  $195.465 \text{ cm}^2$



### EXERCISE - 10.2

1. A toy is in the form of a cone mounted on a hemisphere. The diameter of the base and the height of the cone are 6 cm and 4 cm respectively. Determine the surface area of the toy. [use  $\pi = 3.14$ ]
2. A solid is in the form of a right circular cylinder with a hemisphere at one end and a cone at the other end. The radius of the common base is 8 cm. and the heights of the cylindrical and conical portions are 10 cm and 6 cm respectively. Find the total surface area of the solid. [use  $\pi = 3.14$ ]

3. A medicine capsule is in the shape of a cylinder with two hemispheres stuck to each of its ends. The length of the capsule is 14 mm. and the width is 5 mm. Find its surface area.

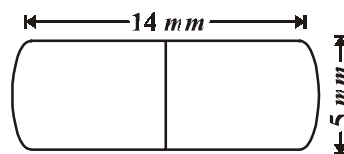

4. Two cubes each of volume  $64 \text{ cm}^3$  are joined end to end together. Find the surface area of the resulting cuboid.
5. A storage tank consists of a circular cylinder with a hemisphere stuck on either end. If the external diameter of the cylinder be 1.4 m. and its length be 8 m. find the cost of painting it on the outside at rate of ₹20 per  $\text{m}^2$ .
6. A sphere, a cylinder and a cone have the same radius. Find the ratio of their curved surface areas.
7. A hemisphere is cut out from one face of a cubical wooden block such that the diameter of the hemisphere is equal to the length of the cube. Determine the surface area of the remaining solid.

8. A wooden article was made by scooping out a hemisphere from each end of a solid cylinder, as shown in the figure. If the height of the cylinder is 10 cm. and its base is of 3.5 cm, find the total surface area of the article.

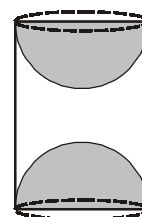

### 10.3 VOLUME OF COMBINATION OF SOLIDS

Let us understand volume through an example.

Suresh runs an industry in a shed which is in the shape of a cuboid surmounted by a half cylinder. The base of the shed is of dimensions  $7\text{ m.} \times 15\text{ m.}$  and the height of the cuboidal portion is  $8\text{ m.}$  Find the volume of air that the shed can hold? Further suppose the machinery in the shed occupies a total space of  $300\text{ m}^3$  and there are 20 workers, each of whom occupies about  $0.08\text{ m}^3$  space on an average. Then how much air is in the shed ?

The volume of air inside the shed (when there are no people or machinery) is given by the volume of air inside the cuboid and inside the half cylinder taken together. The length, breadth and height of the cuboid are  $15\text{ m.}$ ,  $7\text{ m.}$  and  $8\text{ m.}$  respectively. Also the diameter of the half cylinder is  $7\text{ m.}$  and its height is  $15\text{ m.}$

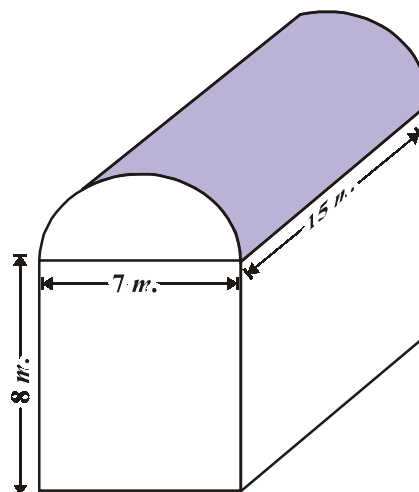

So the required volume = volume of the cuboid +  $\frac{1}{2}$  volume of the cylinder.

$$= \left[ 15 \times 7 \times 8 + \frac{1}{2} \times \frac{22}{7} \times \frac{7}{2} \times \frac{7}{2} \times 15 \right] \text{m}^3$$

$$= 1128.75 \text{m}^3.$$

Next, the total space occupied by the machinery

$$= 300 \text{m}^3.$$

And the total space occupied by the workers

$$= 20 \times 0.08 \text{m}^3$$

$$= 1.6 \text{m}^3$$

Therefore, the volume of the air, when there are machinery and workers

$$= 1128.75 - (300.00 + 1.60)$$

$$= 1128.75 - 301.60 = 827.15 \text{m}^3$$

**Note :** In calculating the surface area of combination of solids, we can not add the surface areas of the two solids because some part of the surface areas disappears in the process of joining them. However, this will not be the case when we calculate the volume. The volume of the solid formed by joining two basic solids will actually be the sum of the volumes of the constituents as we seen in the example above.



**TRY THIS**

1. If the diameter of the cross - section of a wire is decreased by 5%, by what percentage should the length be increased so that the volume remains the same ?
2. Surface area of a sphere and cube are equal. Then find the ratio of their volumes.

Let us see some more examples.

**Example-10.** A solid toy is in the form of a right circular cylinder with hemispherical shape at one end and a cone at the other end. Their common diameter is 4.2 cm and the height of the cylindrical and conical portions are 12cm and 7cm respectively. Find the volume of the solid toy.

(Use  $\pi = \frac{22}{7}$ ).

**Solution :** Let height of the conical portion  $h_1 = 7$ cm

The height of cylindrical portion  $h_2 = 12$  cm

$$\text{Radius } (r) = \frac{4.2}{2} = 2.1 = \frac{21}{10} \text{ cm}$$

Volume of the solid toy

= Volume of the Cone + Volume of the Cylinder + Volume of the Hemisphere.

$$= \frac{1}{3} \pi r^2 h_1 + \pi r^2 h_2 + \frac{2}{3} \pi r^3$$

$$= \pi r^2 \left[ \frac{1}{3} h_1 + h_2 + \frac{2}{3} r \right]$$

$$= \frac{22}{7} \times \left( \frac{21}{10} \right)^2 \times \left[ \frac{1}{3} \times 7 + 12 + \frac{2}{3} \times \frac{21}{10} \right]$$

$$= \frac{22}{7} \times \frac{441}{100} \times \left[ \frac{7}{3} + \frac{12}{1} + \frac{7}{5} \right]$$

$$= \frac{22}{7} \times \frac{441}{100} \times \left[ \frac{35 + 180 + 21}{15} \right]$$

$$= \frac{22}{7} \times \frac{441}{100} \times \frac{236}{15} = \frac{27258}{125} = 218.064 \text{ cm}^3.$$

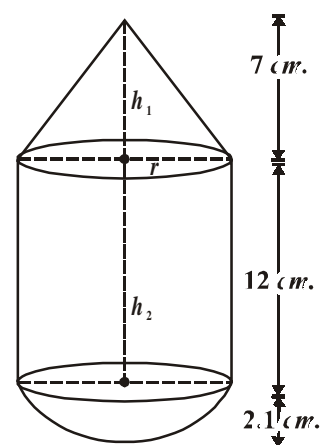

**Example-11.** A cylindrical container is filled with ice-cream whose diameter is 12 cm. and height is 15 cm. The whole ice-cream is distributed to 10 children in equal cones having hemispherical tops. If the height of the conical portion is twice the diameter of its base, find the diameter of the ice-cream cone.

**Solution :** Let the radius of the base of conical ice cream =  $x$  cm

$$\therefore \text{diameter} = 2x \text{ cm}$$

Then, the height of the conical ice-cream

$$= 2 (\text{diameter}) = 2(2x) = 4x \text{ cm}$$

Volume of ice - cream cone

$$= \text{Volume of conical portion} + \text{Volume of hemispherical portion}$$

$$= \frac{1}{3} \pi r^2 h + \frac{2}{3} \pi r^3$$

$$= \frac{1}{3} \pi x^2 (4x) + \frac{2}{3} \pi x^3$$

$$= \frac{4\pi x^3 + 2\pi x^3}{3} = \frac{6\pi x^3}{3}$$

$$= 2\pi x^3 \text{ cm}^3$$

Diameter of cylindrical container = 12 cm

Its height ( $h$ ) = 15 cm

$$\begin{aligned} \therefore \text{Volume of cylindrical container} &= \pi r^2 h \\ &= \pi(6)^2 \cdot 15 \\ &= 540\pi \text{ cm}^3 \end{aligned}$$

Number of children to whom ice-cream is given = 10

$$\frac{\text{Volume of cylindrical container}}{\text{Volume of one ice-cream cone}} = 10$$

$$\Rightarrow \frac{540\pi}{2\pi x^3} = 10$$

$$2\pi x^3 \times 10 = 540\pi$$

$$\Rightarrow x^3 = \frac{540}{2 \times 10} = 27$$

$$\Rightarrow x^3 = 27$$

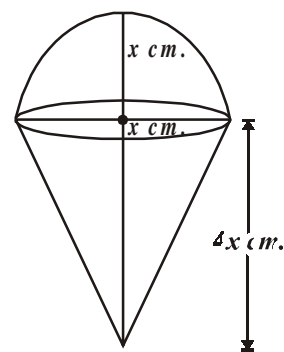

$$\Rightarrow x^3 = 3^3$$

$$\Rightarrow x = 3$$

$\therefore$  Diameter of ice-cream cone  $2x = 2(3) = 6\text{cm}$

**Example-12.** A solid consisting of a right circular cone standing on a hemisphere, is placed upright in a right circular cylinder full of water and touches the bottom. Find the volume of water left in the cylinder, given that the radius of the cylinder is 3 cm. and its height is 6cm. The radius of the hemisphere is 2 cm. and the height of the cone is 4 cm.

$$\left( \text{Take } \pi = \frac{22}{7} \right).$$

**Solution :** In the figure drawn here,

ABCD is a cylinder and LMN is a Hemisphere

OLM is a cone. We know that where a solid consisting of a cone and hemisphere is immersed in the cylinder full of water, then some water equal to the volume of the solid, is displaced.

$$\text{Volume of Cylinder} = \pi r^2 h = \pi \times 3^2 \times 6 = 54 \pi \text{ cm}^3$$

$$\text{Volume of Hemisphere} = \frac{2}{3} \pi r^3 = \frac{2}{3} \times \pi \times 2^3 = \frac{16}{3} \pi \text{ cm}^3$$

$$\text{Volume of Cone} = \frac{1}{3} \pi r^2 h = \frac{1}{3} \times \pi \times 2^2 \times 4 = \frac{16}{3} \pi \text{ cm}^3$$

$$\text{Volume of cone and hemisphere} = \frac{16}{3} \pi + \frac{16}{3} \pi$$

$$= \frac{32}{3} \pi$$

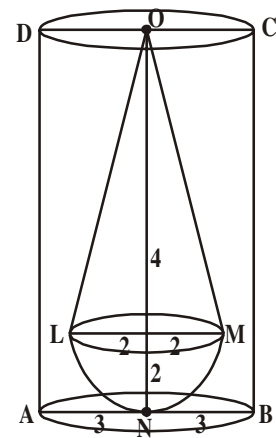

Volume of water left in cylinder

$$= \text{Volume of Cylinder} - \text{Volume of Cone and Hemisphere}$$

$$= \text{Volume of cylinder} - \frac{32\pi}{3}$$

$$= 54\pi - \frac{32\pi}{3}$$

$$= \frac{162\pi - 32\pi}{3} = \frac{130\pi}{3}$$

$$= \frac{130}{3} \times \frac{22}{7} = \frac{2860}{21} = 136.19 \text{ cm}^3$$

**Example-13.** A cylindrical pencil is sharpened to produce a perfect cone at one end with no overall loss of its length. The diameter of the pencil is 1 cm and the length of the conical portion is 2 cm. Calculate the volume of the shavings. Give your answer correct to two

places if it is in decimal  $\left[ \text{use } \pi = \frac{355}{113} \right]$ .

**Solution :** Diameter of the pencil = 1 cm

So, radius of the pencil ( $r$ ) = 0.5 cm

Length of the conical portion =  $h = 2$  cm

Volume of shavings = Volume of cylinder of length 2 cm and base radius 0.5 cm.

– volume of the cone formed by this cylinder

$$\begin{aligned} &= \pi r^2 h - \frac{1}{3} \pi r^2 h = \frac{2}{3} \pi r^2 h \\ &= \frac{2}{3} \times \frac{355}{113} \times (0.5)^2 \times 2 \text{ cm}^3 = 1.05 \text{ cm}^3 \end{aligned}$$



### EXERCISE-10.3

1. An iron pillar consists of a cylindrical portion of 2.8 m. height and 20 cm. in diameter and a cone of 42 cm. height surmounting it. Find the weight of the pillar if  $1 \text{ cm}^3$  of iron weighs 7.5 g.
2. A toy is made in the form of hemisphere surmounted by a right cone whose circular base is joined with the plane surface of the hemisphere. The radius of the base of the cone is 7 cm. and its volume is  $\frac{3}{2}$  of the hemisphere. Calculate the height of the cone and the surface area of the toy correct to 2 places of decimal  $\left( \text{Take } \pi = 3\frac{1}{7} \right)$ .
3. Find the volume of the largest right circular cone that can be cut out of a cube whose edge is 7 cm.



4. A cylindrical tub of radius 5cm and length 9.8 cm is full of water. A solid in the form of right circular cone mounted on a hemisphere is immersed into the tub. The radius of the hemisphere is 3.5 cm and height of cone outside the hemisphere is 5cm. Find the volume

of water left in the tub  $\left( \text{Take } \pi = \frac{22}{7} \right)$ .

5. In the adjacent figure, the height of a solid cylinder is 10 cm and diameter is 7cm. Two equal conical holes of radius 3cm and height 4 cm are cut off as shown the figure. Find the volume of the remaining solid.

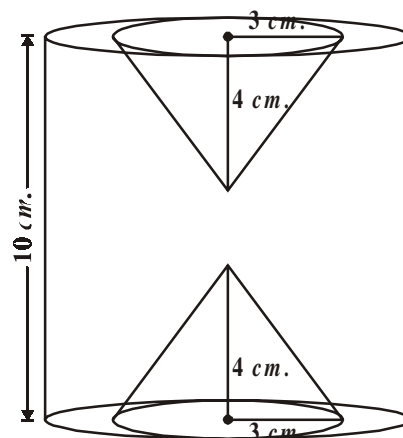

6. Spherical Marbles of diameter 1.4 cm. are dropped into a cylindrical beaker of diameter 7 cm., which contains some water. Find the number of marbles that should be dropped in to the beaker, so that water level rises by 5.6 cm.
7. A pen stand is made of wood in the shape of cuboid with three conical depressions to hold the pens. The dimensions of the cuboid are 15cm by 10 cm by 3.5 cm. The radius of each of the depression is 0.5 cm and the depth is 1.4cm. Find the volume of wood in the entire stand.



### 10.4 CONVERSION OF SOLID FROM ONE SHAPE TO ANOTHER



A women self help group (DWACRA) prepares candles by melting down cuboid shape wax. In gun factories spherical bullets are made by melting solid cube of lead, goldsmith prepares various ornaments by melting cuboid gold biscuits. In all these cases, the shapes of solids are converted into another shape. In this process, the volume always remains the same.

How does this happen? If you want a candle of any special shape, you have to give heat to the wax in metal container till it is completely melted into liquid. Then you pour it into another container which has the special shape that you want.

For example, lets us take a candle in the shape of solid cylinder, melt it and pour whole of

the molton wax into another container shaped like a sphere. On cooling, you will obtain a candle in the shape of sphere. The volume of the new candle will be the same as the volume of the earlier candle. This is what we have to remember when we come across objects which are converted from one shape to another, or when a liquid which originally filled a container of a particular shape is poured into another container of a different shape or size as you observe in the following figures.

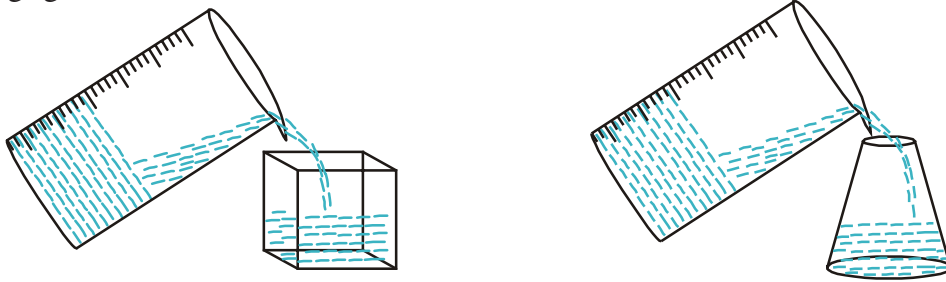

### THINK- DISCUSS

Which barrel shown in the adjacent figure can hold more water? Discuss with your friends.

To understand what has been discussed, let us consider some examples.

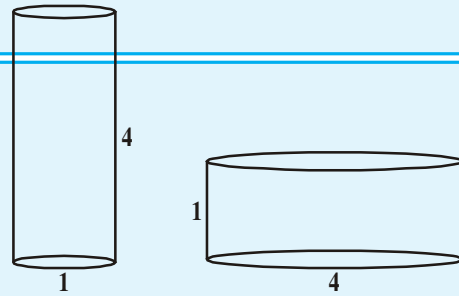

**Example-14.** A cone of height 24cm and radius of base 6cm is made up of modelling clay. A child reshapes it in the form of a sphere. Find the radius of the sphere.

**Solution :** Volume of cone =  $\frac{1}{3} \times \pi \times 6 \times 6 \times 24 \text{ cm}^3$

If  $r$  is the radius of the sphere, then its volume is  $\frac{4}{3} \pi r^3$

Since the volume of clay in the form of the cone and the sphere remains the same, we have

$$\frac{4}{3} \pi r^3 = \frac{1}{3} \pi \times 6 \times 6 \times 24$$

$$r^3 = 3 \times 3 \times 24 = 3 \times 3 \times 3 \times 8$$

$$r^3 = 3^3 \times 2^3$$

$$r = 3 \times 2 = 6$$

Therefore the radius of the sphere is 6cm.





**Do This**

1. A copper rod of diameter 1 cm. and length 8 cm. is drawn into a wire of length 18m of uniform thickness. Find the thickness of the wire.
2. Pravali house has a water tank in the shape of a cylinder on the roof. This is filled by pumping water from a sump (an under ground tank) which is in the shape of a cuboid. The sump has dimensions 1.57 m. × 1.44 m. × 9.5 cm. The water tank has radius 60 cm. and height 95 cm. Find the height of the water left in the sump after the water tank has been completely filled with water from the sump which had been full of water. Compare the capacity of the tank with that of the sump. ( $\pi = 3.14$ )

**Example-15.** The diameter of the internal and external surfaces of a hollow hemispherical shell are 6 cm. and 10 cm. respectively. It is melted and recast into a solid cylinder of diameter 14 cm. Find the height of the cylinder.

**Solution :** Radius of Hollow hemispherical shell =  $\frac{10}{2} = 5 \text{ cm.} = R$

Internal radius of hollow hemispherical shell =  $\frac{6}{2} = 3 \text{ cm.} = r$

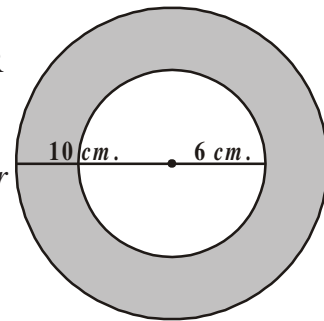

Volume of hollow hemispherical shell  
= External volume - Internal volume

$$= \frac{2}{3} \pi R^3 - \frac{2}{3} \pi r^3$$

$$= \frac{2}{3} \pi (R^3 - r^3)$$

$$= \frac{2}{3} \pi (5^3 - 3^3)$$

$$= \frac{2}{3} \pi (125 - 27)$$

$$= \frac{2}{3} \pi \times 98 \text{ cm}^3 = \frac{196\pi}{3} \text{ cm}^3 \quad \dots(1)$$

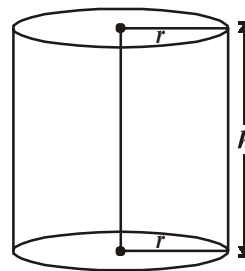

Since, this hollow hemispherical shell is melted and recast into a solid cylinder. So their volumes must be equal

Diameter of cylinder = 14 cm. (Given)

So, radius of cylinder = 7 cm.

Let the height of cylinder =  $h$

$$\begin{aligned} \therefore \text{volume of cylinder} &= \pi r^2 h \\ &= \pi \times 7 \times 7 \times h \text{ cm}^3 = 49\pi h \text{ cm}^3 \quad \dots(2) \end{aligned}$$

According to given condition

volume of Hollow hemispherical shell = volume of solid cylinder

$$\begin{aligned} \frac{196}{3}\pi &= 49\pi h \quad [\text{From equation (1) and (2)}] \\ \Rightarrow h &= \frac{196}{3 \times 49} = \frac{4}{3} \text{ cm.} \end{aligned}$$

Hence, height of the cylinder = 1.33 cm.

**Example-16.** A hemispherical bowl of internal radius 15 cm. contains a liquid. The liquid is to be filled into cylindrical bottles of diameter 5 cm. and height 6 cm. How many bottles are necessary to empty the bowl ?

**Solution :** Volume of hemisphere =  $\frac{2}{3}\pi r^3$

Internal radius of hemisphere  $r = 15$  cm.

$\therefore$  volume of liquid contained in hemispherical bowl

$$\begin{aligned} &= \frac{2}{3}\pi(15)^3 \text{ cm}^3 \\ &= 2250\pi \text{ cm}^3. \end{aligned}$$

This liquid is to be filled in cylindrical bottles and the height of each bottle ( $h$ ) = 6 cm.

Radius of cylindrical bottle ( $R$ ) =  $\frac{5}{2}$  cm.

$\therefore$  Volume of 1 cylindrical bottle =  $\pi R^2 h$

$$\begin{aligned} &= \pi \times \left(\frac{5}{2}\right)^2 \times 6 \\ &= \pi \times \frac{25}{4} \times 6 \text{ cm}^3 = \frac{75}{2}\pi \text{ cm}^3 \end{aligned}$$

$$\begin{aligned} \text{Number of cylindrical bottles required} &= \frac{\text{Volume of hemispherical bowl}}{\text{Volume of 1 cylindrical bottle}} \\ &= \frac{2250\pi}{\frac{75}{2}\pi} = \frac{2 \times 2250}{75} = 60. \end{aligned}$$

**Example-17.** The diameter of a metallic sphere is 6cm. It is melted and drawn into a wire having diameter of the cross section as 0.2 cm. Find the length of the wire.

**Solution :** We have, diameter of metallic sphere = 6cm

∴ Radius of metallic sphere = 3cm

Also, we have,

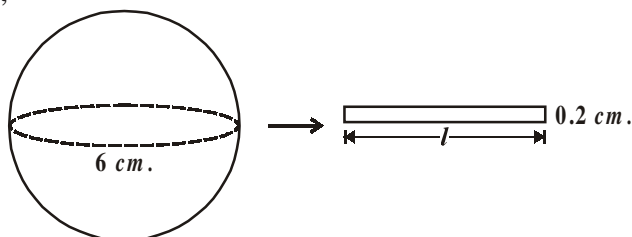

Diameter of cross - section of cylindrical wire = 0.2 cm.

Radius of cross section of cylinder wire = 0.1 cm.

Let the length of wire be  $l$  cm.

Since the metallic sphere is converted into a cylindrical shaped wire of length  $h$  cm.

∴ Volume of the metal used in wire = Volume of the sphere

$$\pi \times (0.1)^2 \times h = \frac{4}{3} \times \pi \times 3^3$$

$$\pi \times \left(\frac{1}{10}\right)^2 \times h = \frac{4}{3} \times \pi \times 27$$

$$\pi \times \frac{1}{100} \times h = 36\pi$$

$$h = \frac{36\pi \times 100}{\pi} \text{ cm}$$

$$= 3600 \text{ cm.} = 36 \text{ m.}$$

Therefore, the length of the wire is 36 m.



**Example-18.** How many spherical balls can be made out of a solid cube of lead whose edge measures 44 cm and each ball being 4 cm. in diameter.

**Solution :** Side of lead cube = 44 cm.

$$\text{Radius of spherical ball} = \frac{4}{2} \text{ cm.} = 2 \text{ cm.}$$

$$\text{Now volume of a spherical bullet} = \frac{4}{3} \pi r^3$$

$$= \frac{4}{3} \times \frac{22}{7} \times 2^3 \text{ cm}^3$$

$$= \frac{4}{3} \times \frac{22}{7} \times 8 \text{ cm}^3$$

$$\text{Volume of } x \text{ sperical bullet} = \frac{4}{3} \times \frac{22}{7} \times 8 \times x \text{ cm}^3$$

It is clear that volume of  $x$  sperical bullets = Volume of lead cube

$$\Rightarrow \frac{4}{3} \times \frac{22}{7} \times 8 \times x = (44)^3$$

$$\Rightarrow \frac{4}{3} \times \frac{22}{7} \times 8 \times x = 44 \times 44 \times 44$$

$$\Rightarrow x = \frac{44 \times 44 \times 44 \times 3 \times 7}{4 \times 22 \times 8}$$

$$x = 2541$$

Hence, total number of sperical bullets = 2541.

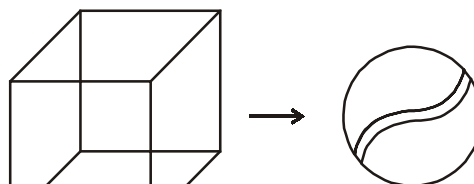

**Example-19.** A women self help group (DWACRA) is supplied a rectangular solid (cuboid shape) of wax with diameters 66 cm., 42 cm., 21 cm., to prepare cylindrical candles each 4.2 cm. in diameter and 2.8 cm. of height. Find the number of candles.

**Solution :** Volume of wax in the rectangular solid =  $lbh$

$$= (66 \times 42 \times 21) \text{ cm}^3.$$

$$\text{Radius of cylindrical candle} = \frac{4.2}{2} \text{ cm.} = 2.1 \text{ cm.}$$

Height of cylindrical candle = 2.8 cm.

$$\begin{aligned} \text{Volume of candle} &= \pi r^2 h \\ &= \frac{22}{7} \times (2.1)^2 \times 2.8 \end{aligned}$$

$$\text{Volume of } x \text{ cylindrical wax candles} = \frac{22}{7} \times 2.1 \times 2.1 \times 2.8 \times x$$

$\therefore$  Volume of  $x$  cylindrical candles = volume of wax in rectangular shape

$$\therefore \frac{22}{7} \times 2.1 \times 2.1 \times 2.8 \times x = 66 \times 42 \times 21$$

$$\begin{aligned} x &= \frac{66 \times 42 \times 21 \times 7}{22 \times 2.1 \times 2.1 \times 2.8} \\ &= 1500 \end{aligned}$$

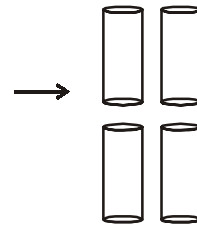
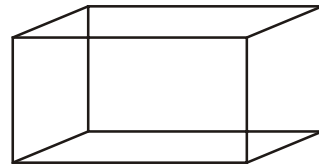

Hence, the number of cylindrical wax candles is 1500.



### EXERCISE - 10.4

1. A metallic sphere of radius 4.2 cm. is melted and recast into the shape of a cylinder of radius 6cm. Find the height of the cylinder.
2. Metallic spheres of radius 6 cm., 8 cm. and 10 cm. respectively are melted to form a single solid sphere. Find the radius of the resulting sphere.
3. A 20m deep well with diameter 7 m. is dug and the earth from digging is evenly spread out to form a platform 22 m. by 14 m. Find the height of the platform.
4. A well of diameter 14 m. is dug 15 m. deep. The earth taken out of it has been spread evenly all around it in the shape of a circular ring of width 7 m. to form an embankment. Find the height of the embankment.
5. A container shaped like a right circular cylinder having diameter 12 cm. and height 15 cm. is full of ice cream. The icecream is to be filled into cones of height 12 cm. and diameter 6 cm., having a hemispherical shape on the top. Find the number of such cones which can be filled with ice cream.
6. How many silver coins, 1.75 cm. in diameter and thickness 2 mm., need to be melted to form a cuboid of dimensions 5.5 cm.  $\times$  10 cm.  $\times$  3.5 cm.?
7. A vessel is in the form of an inverted cone. Its height is 8 cm. and the radius of its top is 5 cm. It is filled with water up to the rim. When lead shots, each of which is a sphere of

radius 0.5cm are dropped into the vessel,  $\frac{1}{4}$  of the water flows out. Find the number of lead shots dropped into the vessel.

8. A solid metallic sphere of diameter 28 cm is melted and recast into a number of smaller cones, each of diameter  $4\frac{2}{3}$  cm and height 3cm. Find the number of cones so formed.



### OPTIONAL EXERCISE

[This exercise is not meant for examination purpose]

1. A golf ball has diameter equal to 4.1 cm. Its surface has 150 dimples each of radius 2 mm. Calculate total surface area which is exposed to the surroundings. (Assume that the dimples are all hemispherical)  $\left[\pi = \frac{22}{7}\right]$
2. A cylinder of radius 12 cm. contains water to a depth of 20 cm. A spherical iron ball is dropped in to the cylinder and thus the level of water is raised by 6.75 cm. Find the radius of the ball.  $\left[\pi = \frac{22}{7}\right]$
3. A solid toy is in the form of a right circular cylinder with a hemispherical shape at one end and a cone at the other end. Their common diameter is 4.2 cm. and height of the cylindrical and conical portion are 12 cm. and 7 cm. respectively. Find the volume of the solid toy.  $\left[\pi = \frac{22}{7}\right]$
4. Three metal cubes with edges 15 cm., 12 cm. and 9 cm. respectively are melted together and formed into a simple cube. Find the diagonal of this cube.
5. A hemispherical bowl of internal diameter 36 cm. contains a liquid. This liquid is to be filled in cylindrical bottles of radius 3 cm. and height 6 cm. How many bottles are required to empty the bowl?



### WHAT WE HAVE DISCUSSED.

1. The volume of the solid formed by joining two basic solids is the sum of the volumes of the constituents.
2. In calculating the surface area of a combination of solids, we can not add the surface area of the two constituents, because some part of the surface area disappears in the process of joining them.