

E

SUBJECT CODE BOOKLET CODE

6**A**

**2012 (II)
ENGINEERING SCIENCES
TEST BOOKLET**

Time : 3:00 Hours

Maximum Marks: 200

INSTRUCTIONS

1. This Test Booklet contains one hundred and fifteen (20 Part 'A' + 25 Part 'B' + 70 Part 'C') Multiple Choice Questions (MCQs). You are required to answer a maximum of 15, 20 and 20 questions from part 'A' 'B' and 'C' respectively. If more than required number of questions are answered, only first 15, 20 and 20 questions in Parts 'A' 'B' and 'C' respectively, will be taken up for evaluation.
2. Answer sheet has been provided separately. Before you start filling up your particulars, please ensure that the booklet contains requisite number of pages and that these are not torn or mutilated. If it is so, you may request the Invigilator to change the booklet. Likewise, check the answer sheet also. Sheets for rough work have been appended to the test booklet.
3. Write your Roll No., Name, Your address and Serial Number of this Test Booklet on the Answer sheet in the space provided on the side 1 of Answer sheet. Also put your signatures in the space identified.
4. **You must darken the appropriate circles with a pencil related to Roll Number, Subject Code, Booklet Code and Centre Code on the OMR answer sheet. It is the sole responsibility of the candidate to meticulously follow the instructions given on the Answer Sheet, failing which, the computer shall not be able to decipher the correct details which may ultimately result in loss, including rejection of the OMR answer sheet.**
5. Each question in Part 'A' carries 2 marks, Part 'B' 3.5 marks and Part 'C' 5 marks respectively. There will be negative marking @ 25% for each wrong answer.
6. Below each question in Part 'A', 'B' and 'C' four alternatives or responses are given. Only one of these alternatives is the "correct" option to the question. You have to find, for each question, the correct or the best answer.
7. **Candidates found copying or resorting to any unfair means are liable to be disqualified from this and future examinations.**
8. Candidate should not write anything anywhere except on answer sheet or sheets for rough work.
9. After the test is over, you MUST hand over the Test Booklet and the answer sheet (OMR) to the invigilator.
10. Use of scientific calculator without data connectivity is permitted.

Roll No.....

Name

I have verified all the information
filled in by the candidate......
Signature of the Invigilator

S/75 POK/12—6AE—1B

PART A

1. What is the number of distinct arrangements of the letters of the word UGCCSIR so that U and I cannot come together?

1. 2520 2. 720 3. 1520 4. 1800

2. Suppose the sum of the seven positive numbers is 21. What is the minimum possible value of the average of the squares of these numbers?

1. 63 2. 21 3. 9 4. 7

3. Let

$$A = \frac{1^{13} + 2^{13} + 3^{13} + \dots + 100^{13}}{100}, \quad B = \frac{1^{13} + 3^{13} + 5^{13} + \dots + 99^{13}}{50}, \quad C = \frac{2^{13} + 4^{13} + 6^{13} + \dots + 100^{13}}{50}$$

Which of the following is true?

1. $B < C < A$ 2. $A < B < C$ 3. $B < A < C$ 4. $C < A < B$

4. Which of the following numbers is the largest?

$$2^{3^4}, 2^{4^3}, 3^{2^4}, 3^{4^2}, 4^{2^3}, 4^{3^2}$$

1. 2^{3^4} 2. 3^{4^2} 3. 4^{3^2} 4. 4^{2^3}

5. The cube ABCDEFGH in the figure has each edge equal to a . The area of the triangle with vertices at A, C and F is

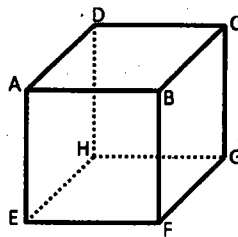

1. $\frac{\sqrt{3}}{4}a^2$ 2. $\frac{\sqrt{3}}{2}a^2$ 3. $\sqrt{3}a^2$ 4. $2\sqrt{3}a^2$

6. If the sum of the next two terms of the series below is x , what is the value of $\log_2 x$?
 2, -4, 8, -16, 32, -64, 128,

1. 128 2. 10 3. 256 4. 8

7.

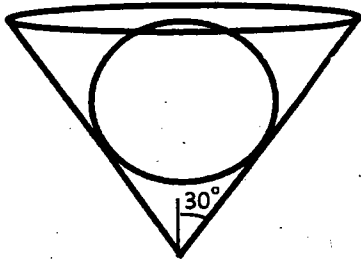

A conical vessel with semi-vertical angle 30° and height 10.5 cm has a thin lid. A sphere kept inside it touches the lid. The radius of the sphere in cm is

1. 3.5 2. 5 3. 6.5 4. 7

8. A circle of radius 5 units in the XY plane has its centre in the first quadrant, touches the x -axis and has a chord of length 6 units on the y -axis. The coordinates of its centre are

1. (4,6) 2. (3,5) 3. (5,4) 4. (4,5)

9. A wire of length 6m is used to make a tetrahedron of each edge 1m, using only one strand of wire for each edge. The minimum number of times the wire has to be cut is

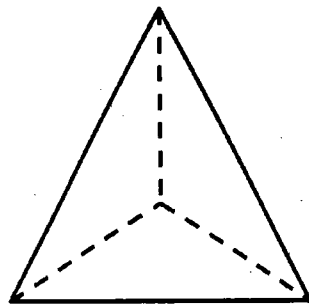

1. 2 2. 3 3. 1 4. 0

10. What does this diagram demonstrate?

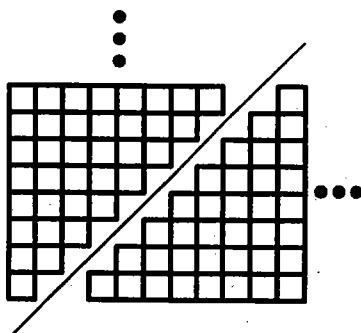

1. $1+2+3+\dots+n = \frac{n \cdot (n+1)}{2}$
2. $1^2+2^2+3^2+\dots+n^2 = \frac{n \cdot (n+1) \cdot (2n+1)}{6}$
3. $1+3+\dots+(2n-1) = n^2$
4. $2^2+4^2+\dots+(2n)^2 = \frac{2 \cdot n(n+1)(2n+1)}{3}$

11. Suppose there are socks of N different colors in a box. If you take out one sock at a time, what is the maximum number of socks that you have to take out before a matching pair is found? Assume that N is an even number.

1. N
2. $N+1$
3. $N-1$
4. $N/2$

12. At what time after 4 O' clock, the hour and the minute hands will lie opposite to each other?

1. 4-50' - 31"
2. 4-52' - 51"
3. 4-53' - 23"
4. 4-54' - 33"

13. Which of the following curves just touches the x axis?

1. $y = x^2 - x + 1$
2. $y = x^2 - 2x + 2$
3. $y = x^2 - 10x + 25$
4. $y = x^2 - 7x + 12$

14. Suppose we make N identical smaller spheres from a big sphere. The total surface area of the smaller spheres is X times the total surface area of the big sphere, where X is

1. \sqrt{N} 2. 1 3. $N^{1/3}$ 4. N^3

15. What is the next number in the sequence 24, 30, 33, 39, 51,-----?

1. 57 2. 69 3. 54 4. 81

16. Four lines are drawn on a plane with no two parallel and no three concurrent. Lines are drawn joining the points of intersection of the previous four lines. The number of new lines obtained this way is

1. 3 2. 5 3. 12 4. 2

17.

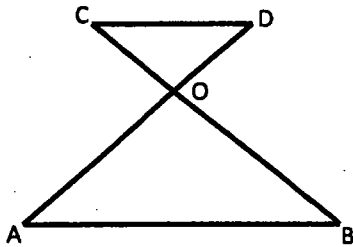

If AB is parallel to CD and $AO=2OD$, then the area of triangle OAB is bigger than the area of triangle OCD by a factor of

1. 2 2. 3 3. 4 4. 8

18. Amar, Akbar and Anthony are three friends, one of whom is a doctor, another is an engineer and the third is a professor. Amar is not an engineer. Akbar is the shortest. The tallest person is a doctor. The engineer's height is the geometric mean of the heights of the other two. Then which of the following is true?

1. Amar is a doctor and he is the tallest
 2. Akbar is a professor and he is the tallest
 3. Anthony is an engineer and he is shortest
 4. Anthony is a doctor and he is the tallest

19. If 100 cats catch 100 mice in 100 minutes, then how long will it take for 7 cats to catch 7 mice?

1. $100/7$ minutes
2. 100 minutes
3. $49/100$ /minutes
4. 7 minutes

20.

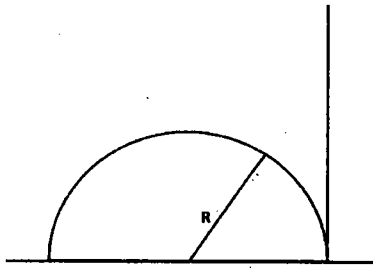

A semi-circular arch of radius R has a vertical pole put on the ground together with one of its legs. An ant on the top of the arch finds the angular height of the tip of the pole to be 45° . The height of the pole is

1. $\sqrt{2}R$
2. $\sqrt{3}R$
3. $\sqrt{4}R$
4. $\sqrt{5}R$

PART B

MATHEMATICS

21. The value of

$$\lim_{h \rightarrow 0} \frac{2^{8 \cosh h}}{8h} \left[\sin^8 \left(\frac{\pi}{6} + h \right) - \sin^8 \frac{\pi}{6} \right]$$

is

(1) 1

(2) $\frac{1}{2}$

(3) $\frac{\sqrt{3}}{2}$

(4) $\sqrt{3}$

22. The number of distinct real roots of the equation $13x^{13} - e^{-x} - 1 = 0$ is

(1) 0

(2) 1

(3) 2

(4) 13

23. The minimum value of the function $f: \mathbb{R} \rightarrow \mathbb{R}$ defined by $f(x) = \int_{-2}^{x^2-2x} e^t e^{t^2} dt$ is

(1) $f(0)$

(2) $f(1)$

(3) $f(2)$

(4) $f(-2)$

24. Let $a_n = \frac{\cos n}{n^2}$ and $b_n = \frac{\cos n}{n^2} \left(\sin \frac{1}{n} - 2 \right)$ for $n \in \mathbb{N}$. Then

(1) $\sum_{n=1}^{\infty} a_n$ converges and $\sum_{n=1}^{\infty} b_n$ diverges

(2) $\sum_{n=1}^{\infty} b_n$ converges and $\sum_{n=1}^{\infty} a_n$ diverges

(3) $\sum_{n=1}^{\infty} a_n$ and $\sum_{n=1}^{\infty} b_n$ converge

(4) $\sum_{n=1}^{\infty} a_n$ and $\sum_{n=1}^{\infty} b_n$ diverge

25. Let S be the sphere $x^2 + y^2 + z^2 = 1$. The value of the surface integral

$$\iint_S (x \sin y, \cos^2 x, 2z - z \sin y) \cdot (x, y, z) \, d\sigma$$
 is

(1) $\frac{\pi}{3}$

(2) $\frac{2\pi}{3}$

(3) $\frac{4\pi}{3}$

(4) $\frac{8\pi}{3}$

26. The value of the integral

$$\int_{|z|=1} \frac{\cos z \, dz}{z(z-2)(z-4)}$$
 is

- (1) $\frac{\pi i}{4}$ (2) $\frac{\pi i}{2}$ (3) πi (4) $2\pi i$

27. Let A be a 2×2 matrix. Suppose $\begin{pmatrix} 2 \\ -1 \end{pmatrix}$ and $\begin{pmatrix} 1 \\ 0 \end{pmatrix}$ are eigen vectors corresponding to the eigen values 1 and 2 of A respectively. Then A is

- (1) $\begin{bmatrix} 2 & 1 \\ -1 & 0 \end{bmatrix}$ (2) $\begin{bmatrix} 1 & 1 \\ 0 & 2 \end{bmatrix}$ (3) $\begin{bmatrix} 2 & 2 \\ 0 & 1 \end{bmatrix}$ (4) $\begin{bmatrix} 1 & 0 \\ 5 & 2 \end{bmatrix}$

28. Consider the ordinary differential equation $y' = \frac{4+y^2}{1+x^2}$. If $y(1) = 2$ then $y(2)$ is

- (1) 1 (2) 5 (3) 14 (4) 21

29. Let $D = \{(x_1, x_2, x_3, x_4) : x_i = 0 \text{ or } 1 \text{ for } i = 1, 2, 3, 4\}$. A vector is chosen at random from the set D. The probability that the product of the first and third coordinate is 0, is

- (1) $\frac{1}{4}$ (2) $\frac{3}{4}$ (3) $\frac{1}{2}$ (4) $\frac{3}{8}$

30. The differential equation for which $x, x \ln x$ and x^2 are linearly independent solutions is

- (1) $x^3 y''' + x^2 y'' - 3xy' + 3y = 0$ (2) $x^3 y''' - 2x^2 y'' + 3xy' - 6y = 0$
 (3) $x^3 y''' - x^2 y'' + 2xy' - 2y = 0$ (4) $y''' - y'' + 2y' - 3 = 0$

ENGINEERING APTITUDE

31. Which of the following statements is true regarding the effect of earth on the capacitance of single-phase and three-phase transmission lines?

- (1) Ideally the presence of the earth does not affect the capacitance.
 (2) Ideally the earth increases the capacitance but for practical values of heights of conductors above the ground, this enhancement can be neglected.
 (3) Ideally, the earth reduces the capacitance but for practical values of heights of conductors above the ground, this reduction can be neglected.
 (4) Ideally, the presence of earth enhances the capacitance significantly and for practical value of heights of conductors above the ground, this enhancement cannot be neglected.

32. Consider a uniformly charged sphere of radius, R . The charge per unit volume is ρ . The magnitude of the electric field at a distance of r from the centre of the sphere ($r < R$), is given by: (ϵ_0 is the permittivity of free space)
- (1) $E = \rho r / 3\epsilon_0$ (2) $E = \rho r^2 / 3\epsilon_0$
(3) $E = \rho R^3 / 4\pi\epsilon_0 r^2$ (4) $E = \rho r / 4\pi\epsilon_0$
33. A long current carrying conductor having radius R , is carrying a uniformly distributed current through its cross-section. The magnetic field intensity inside the conductor is H_i while the magnetic field intensity outside the conductor is H_o . Which of the following statements is true?
- (1) Both H_i and H_o are inversely proportional to the distance from the centre of the conductor.
(2) Both H_i and H_o are proportional to the distance from the centre of the conductor
(3) H_i is proportional to the distance from the centre of the conductor and H_o varies inversely with the distance from the centre of the conductor
(4) H_i varies inversely with the distance from the centre of the conductor and H_o is proportional to the distance from the centre of the conductor.
34. The properties of Monoclinic crystal system are
- (1) $a \neq b \neq c$, $\alpha \neq \beta \neq \gamma$, one 2-fold rotational axis
(2) $a \neq b \neq c$, $\alpha = \beta = 90 \neq \gamma$, two 2-fold rotational axis
(3) $a \neq b \neq c$, $\alpha = \gamma = 90 \neq \beta$, one 2-fold rotational axis
(4) $a \neq b \neq c$, $\alpha = \gamma = 90 \neq \beta$, two 2-fold rotational axis
35. In an x-ray diffraction pattern, the first order reflection from one of the atomic planes in nickel crystal appears at 62.13° when x-rays of wave length of 0.1542 nm was used. What are the indices of the plane if the lattice parameter of nickel is 0.352 nm?
- (1) 111 (2) 200 (3) 220 (4) 400
36. The number average molecular weight of polyvinyl chloride (PVC), when its degree of polymerization is 340, is (atomic weights of C, H and Cl are 12.01, 1.01 and 35.45 g/mol, respectively)
- (1) 20563 (2) 21250 (3) 32959 (4) none of these
37. For a flow to be incompressible
- (1) density must be constant.
(2) velocity field must be divergence free.
(3) vorticity vector must be a null vector.
(4) streamline, streakline and pathline are identical.

38. A small mass m is tied to a string and swung in the anticlockwise direction about the center P of a circle of radius r at a constant speed s (see Figure). When it is at point A , the string snaps off. Assume that the air offers no drag on the mass. Neglect the effect of gravity. What are the coordinates (x, y) of the mass t seconds after the string snaps?

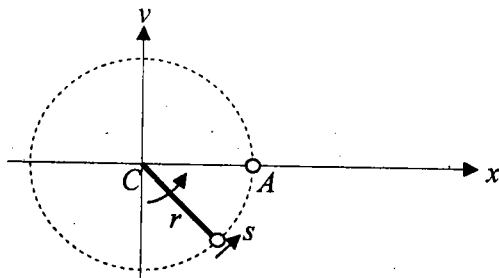

- (1) $\left(r + \frac{ms^2t^2}{2r}, st\right)$ (2) $\left(r + \frac{ms^2t^2}{2r}, 0\right)$ (3) (r, st) (4) $\left(\frac{ms^2t^2}{2r}, st\right)$

39. A cylinder (radius r , length L , and mass m) is kept stationary at point A on an inclined plane. If it is released to roll down the slope (without slipping) by a height h between points A and B , what would be its velocity when it reaches point B ?

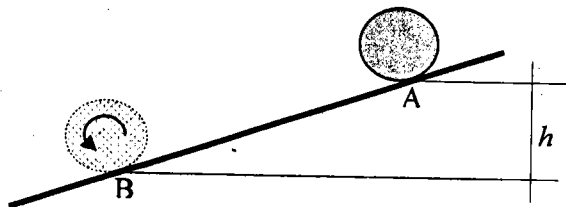

- (1) $\sqrt{2gh}$ (2) $\sqrt{\frac{4}{3}gh}$ (3) \sqrt{gh} (4) $\sqrt{\frac{3}{4}gh}$

40. Nitrogen gas is stored in a cylinder of 5 litres volume at a pressure of 200 bar and a temperature of 27°C . A compressibility factor of 1.1 for nitrogen may be assumed at these conditions. Specific gas constant of nitrogen is 0.297 kJ/kgK . The actual mass of nitrogen in the cylinder is approximately

- (1) 100 grams less than that obtained from ideal gas equation of state
 (2) 100 grams more than that obtained from ideal gas equation of state
 (3) 1130 grams less than that obtained from ideal gas equation of state
 (4) 1130 grams more than that obtained from ideal gas equation of state

41. The net change in entropy at the end of a process undergone by a closed system turns out to be zero. The above process

- (1) must be reversible (2) must be reversible and adiabatic
 (3) must be irreversible and adiabatic (4) may be irreversible, involving a net heat transfer

42. When moist air is cooled sensibly in a cooling coil

- (1) Both wet bulb temperature and relative humidity decrease
- (2) Wet bulb temperature decreases and relative humidity increases
- (3) Wet bulb temperature decreases and relative humidity remains constant
- (4) Both wet bulb temperature and relative humidity remain constant

43. A current of 1 A/cm^2 is forced through an n-type Si bar with a resistivity of $1 \Omega\text{-cm}$ at a temperature of 300 K . How long does it take for an electron to drift through the Si bar of 1 mm long if the mobility of electron at 300 K is $1450 \text{ cm}^2/\text{volt-sec}$?

- (1) $69 \mu\text{s}$
- (2) $145 \mu\text{s}$
- (3) 49 ns
- (4) 1 ms

44. The electric field within the space charge region of a PN junction is shown below.

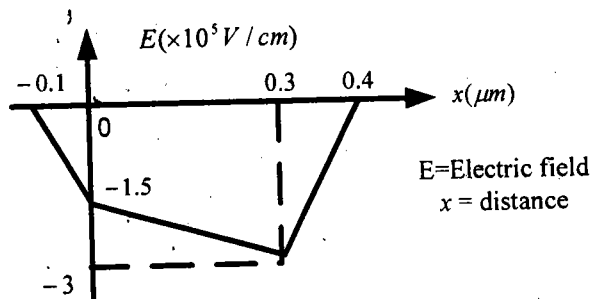

The built-in potential of the PN junction is 0.75 V . Is the diode forward or reverse biased and with how much voltage?

- (1) Forward biased, 1.75 V
- (2) Reverse biased, 0.75 V
- (3) Forward biased, 0.45 V
- (4) Reverse biased, 8.25 V

45. The half-wave rectifier shown below is operating at a frequency of 50 Hz and the RMS value of transformer output voltage is 6.3 V . What is the approximate value of dc output voltage and what is the minimum value of capacitance (C) required to maintain the ripple voltage within 0.25 V ? Assume: $R = 5 \text{ k}\Omega$ and diode voltage drop = 1 V .

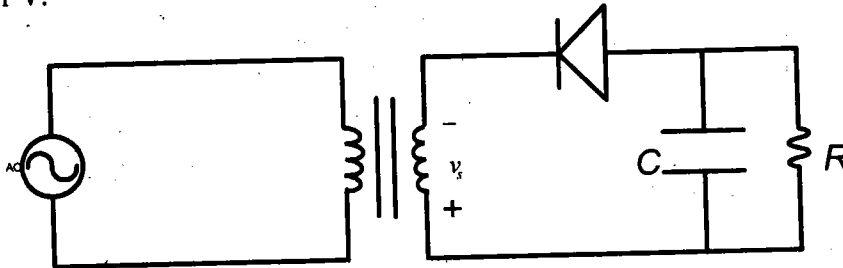

- (1) $-7.9 \text{ V}, 126 \mu\text{F}$
- (2) $7.9 \text{ V}, 126 \mu\text{F}$
- (3) $5.3 \text{ V}, 63 \mu\text{F}$
- (4) $-5.3 \text{ V}, 63 \mu\text{F}$

PART C

COMPUTER SCIENCE & INFORMATION TECHNOLOGY

46. Let A denote the set of positive integers and R be a relation defined by aRb if and only if $b = a + 1$. The transitive closure T of R is

- (1) aTb if and only if a, b are integers and $a \geq 0, b \geq 0$.
- (2) aTb if and only if a and b are integers and $a > 0, b > 0$.
- (3) aTb if and only if a and b are positive integers and $a > b$.
- (4) aTb if and only if a and b are positive integers and $b > a$.

47. In deletion by merging in a Binary Search Tree, when a node with two children is deleted, the right sub-tree of the deleted node may be attached to the node containing largest key in the left sub-tree. If the node 15 is deleted from the tree in Figure 1, we obtain a structure as shown in Figure 2.

The values in the nodes marked X and Y in Figure 2 are

FIGURE 1

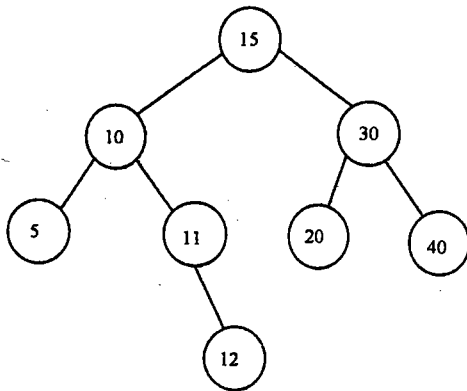
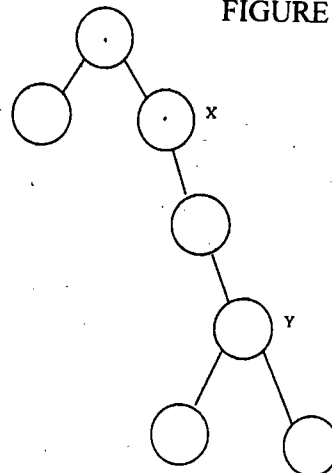

FIGURE 2



- (1) $X = 5, Y = 10$.
- (2) $X = 11, Y = 30$.
- (3) $X = 10, Y = 20$.
- (4) $X = 20, Y = 30$.

48. The priority queue ADT, with operations Insert and Delete Min over a set of integers, is implemented using a linked list and heap data structures. Let the complexity of operations in linked list for Insert and Delete Min be (LI, LD) while the complexity of the operations in Heap be (HI, HD) . Which of the following is TRUE?

- (1) $(LI, LD) = (O(1), O(1)),$
 $(HI, HD) = (O(1), O(\log n)).$
- (2) $(LI, LD) = (O(1), O(n)),$
 $(HI, HD) = (O(1), O(\log n)).$
- (3) $(LI, LD) = (O(1), O(n)),$
 $(HI, HD) = (O(\log n), O(\log n)).$
- (4) $(LI, LD) = (O(n), O(n)),$
 $(HI, HD) = (O(1), O(1)).$

49. Suppose access to an instruction in the cache is 20 times faster than access to an instruction in the main memory. Assume that a requested instruction is found in the cache with probability 0.84, and also assume that if an instruction is not found in the cache, it must first be fetched from the main memory to the cache and then fetched from the cache to be executed. The speedup factor resulting from the presence of the cache is:
- (1) 2 (2) 15.987 (3) 6.82 (4) 4.762
50. If an 8-way set-associative cache is made up of 32 bit words, 4 words per line and 4096 sets, how big is the cache in bytes?
- (1) 12 bytes (2) 512 kilobytes (3) 2 megabytes (4) 10 kilobytes
51. Transaction processing is associated with everything below except
- (1) producing detail, summary, or exception reports.
 (2) recording a business activity.
 (3) confirming an action or triggering a response.
 (4) maintaining data.
52. Which of the following is correct?
- (1) $2^n < n^2 < n^3 < 3^n$ (2) $n \log n < n \log^2 n < n^2 < 2^n$
 (3) $n^3 \log n < n^3 < 3^n < 2^{2n}$ (4) $n < n^2 < n \log n < n^2 \log n$
53. Consider an execution of QUICKSORT with the first item of an array segment acting as pivot or splitter. After 2 passes of running quicksort on the array
 2, 8, 7, 1, 3, 5, 6, 4
 let the resulting sequence be
 $a_1, a_2, a_3, a_4, a_5, a_6, a_7, a_8$.
 Then, which one of the following is TRUE?
- (1) $a_3 = 6, a_6 = 5$ (2) $a_3 = 5, a_6 = 6$
 (3) $a_3 = 2, a_6 = 7$ (4) $a_3 = 7, a_6 = 2$
54. Let P be a Boolean function and $P = A'B + B'A$. Then the function $P \oplus A \oplus P \oplus A \oplus P \oplus B \oplus P \oplus A$ evaluates to
- (1) $A \oplus B$ (2) A (3) B (4) 0

55. Orthogonal arrays allow maximum test coverage from minimum set of test procedures. Suppose there are three parameters A, B, C each of which has one of three possible values 1, 2 or 3. The strength of the orthogonal array is the number of parameters whose combination of values occur only once.

The number of test cases required for an orthogonal array of strength 2 for A, B and C are

- (1) 6 (2) 9 (3) 8 (4) 27

ELECTRICAL SCIENCE

56. The back emf of a separately excited dc motor is estimated and is found to be 180 V when it is running at a speed of 1000 rpm and while rated voltage is applied to its field winding. Neglecting rotational losses, the torque developed by this machine when it is drawing 10A of armature current and while half the rated voltage is applied to its field winding is

- (1) $\frac{54}{\pi}$ Nm (2) $\frac{27}{\pi}$ Nm (3) $\frac{1.8}{\pi}$ Nm (4) $\frac{0.9}{\pi}$ Nm

57. A 400V, three phase, 50Hz, 1420 rpm wound rotor induction motor is having per phase rotor resistance referred to the stator as 0.25Ω and is having per phase standstill rotor reactance referred to the stator as 0.6Ω . While driving a certain load at 1425 rpm, the per phase rotor current referred to the stator is found to be 5 A. Neglecting rotational losses, the torque developed by the machine is

- (1) $\frac{375}{50\pi}$ Nm (2) $\frac{125}{50\pi}$ Nm (3) $\frac{75}{50\pi}$ Nm (4) $\frac{25}{50\pi}$ Nm

58. A diode bridge rectifier connected to a 230 V, 50 Hz single phase sinusoidal ac supply is feeding an R - L load as shown in the figure. The inductive component of the load, L can be considered to be very high so that the load current, i_L can be assumed to be a perfect dc current of magnitude 10 A. The rms value of the source current, i_s is

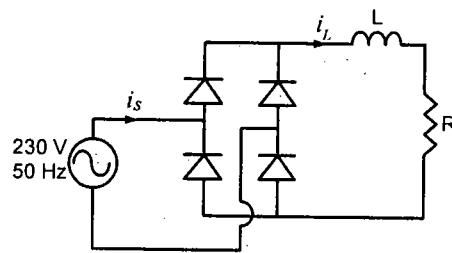

- (1) $\frac{3 \times 10}{2\pi}$ A (2) $\frac{6 \times 10}{\pi}$ A (3) $\frac{3 \times 10}{\pi}$ A (4) 10 A

59. The speed of a 400V, 50 Hz, 1400 rpm, 3-phase induction motor having negligible stator series impedance, is controlled by V/f method of speed control to drive a rated load at 700 rpm. Which of the following statement is true for this case?

- (1) Speed of the rotating magnetic field is 700 rpm and slip speed is 50 rpm
- (2) Speed of the rotating magnetic field is 1500 rpm and slip speed is 800 rpm
- (3) Speed of the rotating magnetic field is 800 rpm and slip speed is 100 rpm
- (4) Speed of the rotating magnetic field is 750 rpm and slip speed is 50 rpm

60. The switch, S of the dc to dc buck converter shown in the figure is operated with a duty cycle of 0.5 at a switching frequency of 5 kHz while it is feeding a certain load. While the input voltage of the converter is maintained at 100 V dc, the steady state average voltage at the output terminals of the converter, V_o is found to be 70 V. Which of the following statements is true for this converter?

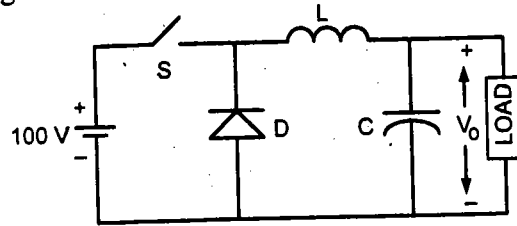

- (1) The converter is operating under continuous mode of conduction
- (2) The converter is operating under discontinuous mode of conduction
- (3) The converter is operating on the boundary of continuous and discontinuous mode of conduction
- (4) The converter is operating in unstable mode of operation

61. In the network shown in the figure, the parallel combination of R and L constitutes the internal impedance of the source whereas the series combination of R_1 and C constitutes the impedance of the load. If the load is drawing maximum power, R_1 and C can be expressed in terms of R and L as

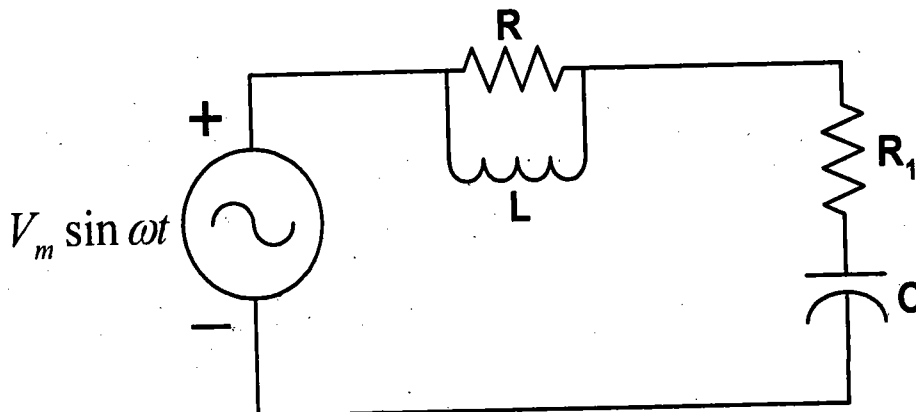

$$(1) R_1 = \frac{R(\omega L)^2}{R^2 + (\omega L)^2}; C = \frac{R^2 + (\omega L)^2}{\omega^2 LR^2} \quad (2) R_1 = \frac{R^2 + (\omega L)^2}{R(\omega L)^2}; C = \frac{\omega^2 LR^2}{R^2 + (\omega L)^2}$$

$$(3) R_1 = \frac{R\omega L^2}{R^2 + (\omega L)^2}; C = \frac{R^2 + (\omega L)^2}{\omega^2 LR^2} \quad (4) R_1 = \frac{R(\omega L)^2}{R^2 + (\omega L)^2}; C = \frac{R^2 + \omega L}{\omega^2 LR^2}$$

62. The state-space model of a dynamic system is given as;

$$\dot{x}_1 = a_1 x_1 + 2x_2 + 2u$$

$$\dot{x}_2 = 3x_1 + a_4 x_2 + 3u$$

What should be the relation between a_4 and a_1 so that this system is controllable?

- (1) $a_4 = a_1$ (2) $a_4 \neq a_1 + 1$ (3) $a_1 = 2a_4$ (4) $a_1 < a_4 + 3$

63. In the single line diagram of a three phase radial distribution system shown in the figure, the line-to-line rated voltage is 11 kV. The per-phase real (P) and reactive (Q) power drawn by the load at the receiving end is 400 kW and 100 kVAR respectively. Considering the receiving end voltage as reference, the power factor and total real power in the three phase system at the sending end are

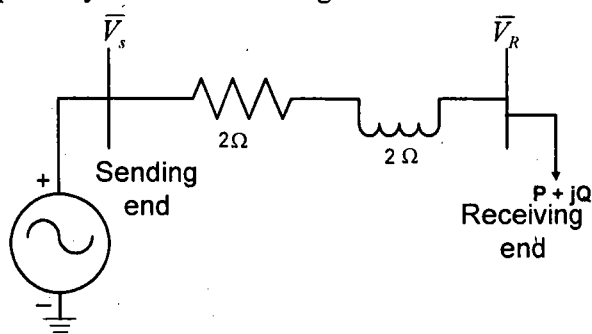

- (1) 0.9 and 1250 kW (2) 0.92 and 1270 kW
(3) 0.966 and 1225 kW (4) 0.82 and 1300 kW

64. In a two-terminal HVDC link, there are two following modes of operation:

Mode 1: Converter 1 acts as a rectifier and converter 2 acts as an inverter.

Mode 2: Converter 1 acts as an inverter and converter 2 acts as a rectifier.

Under these conditions, which one of the following statements is true under normal, steady state operating conditions?

- (1) Converter 1 will always have constant current (CC) control (both in mode 1 and mode 2) while converter 2 will always have constant extinction angle (CEA) control (both in mode 1 and mode 2).
(2) Converter 1 will always have constant extinction angle (CEA) control (both in mode 1 and mode 2) while converter 2 will always have constant current (CC) control (both in mode 1 and mode 2).

- (3) The converter, which acts as a rectifier, will always have constant current (CC) control while the other one (which acts as an inverter) will always have constant extinction angle (CEA) control.
- (4) The converter, which acts as a rectifier, will always have constant extinction angle (CEA) control while the other one (which acts as an inverter) will always have constant current (CC) control.

65. The term 'percentage' in a percentage differential relay denotes the fact that

- (1) The differential operating current is always a fixed percentage of the line current at the primary side of the CTs
- (2) The average restraining current is always a fixed percentage of the line current at the primary side of the CTs
- (3) The number of turns in the operating coil is always a fixed percentage of the number of turns in the restraining coil
- (4) The differential operating current is always a fixed percentage of the average restraining current for given values of number of turns in the operating and the restraining coil.

MATERIAL SCIENCE

66. Suitably connect the improvement of property with the enlisted microstructural features.

- | | |
|-------------|------------------------------------|
| 1. Creep | a. low inclusion volume fraction |
| 2. Fatigue | b. smooth surface finish |
| 3. Fracture | c. large grain size |
| 4. Hardness | d. finely distributed precipitates |

(1) 1-b, 2-c, 3-a, 4-d

(2) 1-c, 2-b, 3-a, 4-d

(3) 1-a, 2-b, 3-c, 4-d

(4) 1-d, 2-b, 3-a, 4-c

67. A zinc rod immersed in an acid solution loses 25mg during 12 hour of exposure. The equivalent current flowing during corrosion is (atomic weight of zinc is 65.4 g/mol)

(1) 0.85 mA

(2) 1.7 mA

(3) 2.5 mA

(4) 3.4 mA

68. The diffusion coefficient of silver in copper at 650°C and 900°C is $5.5 \times 10^{-16} \text{ m}^2/\text{s}$ and $1.3 \times 10^{-13} \text{ m}^2/\text{s}$, respectively. The activation energy for diffusion in J/mol is

(1) 49.2

(2) 85.4

(3) 98.6

(4) 196.7

69 . Match the following properties with the tools used to measure them

- | | |
|----------------------------|-------------------------|
| 1. electrical conductivity | a. calorimetry |
| 2. impact energy | b. four probe technique |
| 3. thermal expansion | c. Izod test |
| 4. specific heat | d. dilatometry |

(1) 1-b, 2-c, 3-d, 4-a

(2) 1-c, 2-a, 3-d, 4-b

(3) 1-d, 2-c, 3-b, 4-a

(4) 1-b, 2-d, 3-c, 4-a

70 . Match the following type of phase diagrams with the reactions involved

- | | |
|---------------|--------------------------------|
| 1. Eutectic | a. $S_1 \rightarrow S_2 + S_3$ |
| 2. Eutectoid | b. $L_1 \rightarrow L_2 + S_1$ |
| 3. Peritectic | c. $L \rightarrow S_1 + S_2$ |
| 4. Monotectic | d. $L + S_1 \rightarrow S_2$ |

(1) 1-a, 2-c, 3-d, 4-b

(2) 1-c, 2-a, 3-d, 4-b

(3) 1-d, 2-c, 3-b, 4-a

(4) 1-c, 2-b, 3-d, 4-a

71 . The yield strength of a polycrystalline material increases from 120 MPa to 220 MPa when its grain size is decreased from 0.04 mm to 0.01 mm. The yield strength of the same material when its grain size is 0.001 mm is

(1) 628 MPa

(2) 652 MPa

(3) 678 MPa

(4) 696 MPa

72 . Match the following type of heat treatment with the phases obtained

- | | |
|-----------------|----------------------------|
| 1. Quenching | a. intermetallic compounds |
| 2. Maraging | b. martensite |
| 3. Tempering | c. bainite |
| 4. Austempering | d. epsilon carbide |

(1) 1-a, 2-c, 3-d, 4-b

(2) 1-b, 2-a, 3-d, 4-c

(3) 1-d, 2-c, 3-b, 4-a

(4) 1-b, 2-d, 3-a, 4-b

73 . Match the following materials with their nature

- | | |
|----------------|-------------------|
| 1. Nb_3Sn | a. semiconductor |
| 2. GaAs | b. dielectric |
| 3. Fe-Si alloy | c. superconductor |
| 4. $BaTiO_3$ | d. soft magnetic |

(1) 1-c, 2-b, 3-a, 4-b

(2) 1-b, 2-a, 3-d, 4-c

(3) 1-c, 2-a, 3-d, 4-b

(4) 1-b, 2-c, 3-a, 4-d

74. An electrochemical cell consists of a nickel electrode in a solution of Ni^{2+} ions on one side, while a cadmium electrode immersed in a solution of Cd^{2+} ions on the other side. If the concentrations of Ni^{2+} and Cd^{2+} ions are 0.002 and 0.6 M, respectively, and assuming Ni is oxidized, the change in the cell potential at 300K is close to (The half cell potentials of Ni and Cd are -0.250 and -0.403 V, respectively, R is 8.314 J/mol.K, F = 96500 Columb/mol)
- (1) 0.073 V (2) -0.08 V (3) -0.153 V (4) -0.226 V
75. What is the vacancy concentration in copper at 727°C? Copper has density of 8.4 g/cc and atomic weight of 63.5 g/mol. (The activation energy for vacancy nucleation is 0.9 eV/atom, Boltzmann constant is 8.62×10^{-5} eV/K and Avogadro number is 6.023×10^{23} atoms/mol)
- (1) 1.7×10^{24} vacancies/ m^3 (2) 2.0×10^{24} vacancies/ m^3
 (3) 2.3×10^{24} vacancies/ m^3 (4) 2.5×10^{24} vacancies/ m^3

FLUID MECHANICS

76. Consider an incompressible flow over a flat plate with a free stream velocity of U. The flow is in the x direction and y is perpendicular to x. The similarity variables are (u/U) and η . The variable η is expressed as $\frac{y}{\sqrt{\nu x/U}}$, where ν refers to kinematic viscosity of the fluid. The boundary layer thickness, δ attains its maximum value of 5.0 as $\eta \rightarrow \infty$, i.e. at $\eta = \eta_{\max} = 5$. The variable u/U is a function of dimensionless stream function, $f(\eta)$ and given as $(u/U) = f'(\eta)$. It is known that at $\eta = 5$, $f(\eta) = 3.2833$ and $f'(\eta) = 0.9915$. What is the ratio of displacement thickness to boundary layer thickness at $\eta = \eta_{\max}$?
- (1) 0.51 (2) 2.12 (3) 0.343 (4) 0.25

77. The gap between the two plates, as shown in the figure, is filled with a fluid of constant density $\rho = 1000 \text{ kg/m}^3$. The top plate moves down with a velocity $V_0 = 1 \text{ mm/s}$. The velocity distribution at the exit is given by

$$u(y) = 4U_0 \left\{ \frac{y}{h(t)} - \left(\frac{y}{h(t)} \right)^2 \right\}$$

Where $h(t)$ is the gap height as a function of time, y is the coordinate as shown in the figure, and U_0 is a function of time.

Given $h(\text{at } t = 0) = h_0 = 1 \text{ mm}$, $L = 1 \text{ mm}$. Which one of the following options is true?

- (1) At $t = 0.1 \text{ s}$, $h = 0.9 \text{ mm}$, $U_0 = 11.11 \text{ mm/s}$
- (2) At $t = 0.1 \text{ s}$, $h = 0.1 \text{ mm}$, $U_0 = 11.11 \text{ mm/s}$
- (3) At $t = 0.1 \text{ s}$, $h = 0.1 \text{ mm}$, $U_0 = 8.33 \text{ mm/s}$
- (4) At $t = 0.1 \text{ s}$, $h = 0.9 \text{ mm}$, $U_0 = 8.33 \text{ mm/s}$

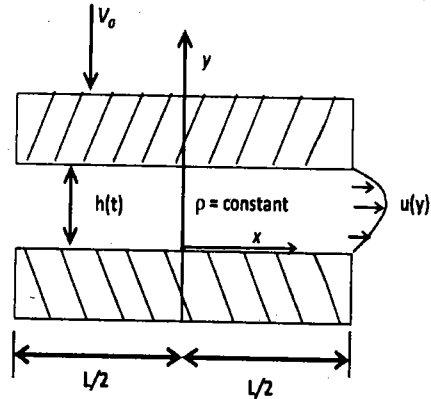

78. Moody's chart presents a functional relation between friction factor against Reynolds number, for different pipe roughness values. One of the following is NOT a feature of this diagram.
- (1) The plot is presented on a log-log axes.
 - (2) In a fully turbulent regime, the pipe roughness is independent of Reynolds number.
 - (3) For laminar flows, the friction factor is directly proportional to Reynolds number.
 - (4) In the turbulent regime for the same value of Reynolds number, as the pipe roughness increases, the value of friction factor increases.
79. A simplified model of an industrial conical tank of height 10 m, which is fully filled with a process fluid is shown in Figure. The top and bottom surfaces are circular with radii 1.0 m and 0.1 m respectively and total cone angle is 60° . The rate of change of surface height $\left(\frac{dh}{dt}\right)$ at a height $(h) = 3.33 \text{ m}$ is given as

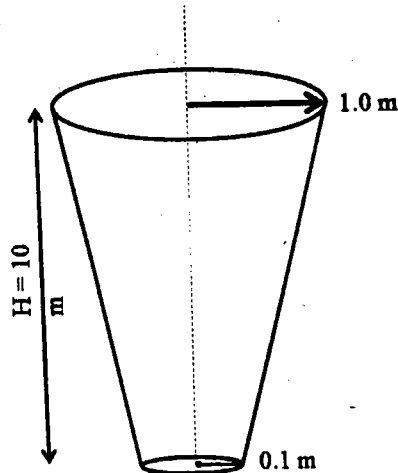

- (1) -23.785 m/s (2) -2.3785 m/s (3) -0.1133 m/s (4) -0.0218 m/s

80. The velocity field and the density field in a diffuser is given by $u = u_0 e^{-x/L}$, $\rho = \rho_0 e^{-2x/L}$ where L is the length of the diffuser. The total rate of change of density at $x = L$ is given by

- (1) 0 (2) $-\frac{\rho_0 u_0}{L} e^{-3}$ (3) $-\frac{2\rho_0 u_0}{L} e^{-3}$ (4) $-\frac{\rho_0 u_0}{2L} e^{-3}$

81. Match the following non-dimensional groups which are categorized into two sets A and B.

- | Set A | Set B |
|-------------------|--|
| 1) Froude number | P) Local acceleration to convective acceleration |
| 2) Weber number | Q) Inertial force to gravity force |
| 3) Euler number | R) Inertial force to pressure force |
| 4) Grashof number | S) Thermal buoyancy force to viscous force |
| | T) Inertial force to surface tension force |

- (1) 1 - T; 2 - Q; 3 - P; 4 - S (2) 1 - Q; 2 - T; 3 - R; 4 - P
 (3) 1 - Q; 2 - T; 3 - P; 4 - S (4) 1 - T; 2 - Q; 3 - S; 4 - P

82. A venturimeter is used to measure flow rate in a pipe of 320 mm diameter. The diameter of the throat of the venturimeter is 160 mm. The differential manometer that connects the pipe and the throat shows a reading of 1 m and specific gravity of gauge fluid is 1.4. If the coefficient of discharge of the venturimeter is 0.98, and the value of g is 9.81 m/s^2 , what is the flow rate?

- (1) $0.017 \text{ m}^3/\text{s}$ (2) $0.037 \text{ m}^3/\text{s}$ (3) $0.057 \text{ m}^3/\text{s}$ (4) $0.077 \text{ m}^3/\text{s}$

83. Consider a two-dimensional incompressible flow over a flat plate with x as the flow direction. The boundary layer grows in y direction. Usually a boundary layer would grow with increasing x . Here uniform suction, v_0 is applied to the plate on the downstream in order to keep the boundary layer thickness constant. The kinematic viscosity is ν . A fully developed situation evolves far downstream. The far field velocity is U_∞ . What is the velocity distribution $u(y)$ in this region?

(1) $u(y) = U_\infty \left[1 - e^{-\frac{v_0 y}{\nu}} \right]$ (2) $u(y) = U_\infty \left[e^{-\frac{v_0 y}{\nu}} \right]$
 (3) $u(y) = U_\infty$ (4) $u(y) = \frac{-v_0}{\nu}$

84. A uniform jet of water is issuing out of a nozzle of diameter $d = 0.01$ m. The jet speed when it exits from the nozzle is 2.0 m/s. The jet impinges on a horizontal flat plate and flows radially outwards in the form of a flat sheet as shown in figure. If the distance between the nozzle and flat plate is 1.5 m, what is the force required to hold the plate in place? Neglect the weight of the plate and the weight of the water sheet. Assume water density as 1000 kg/m³.

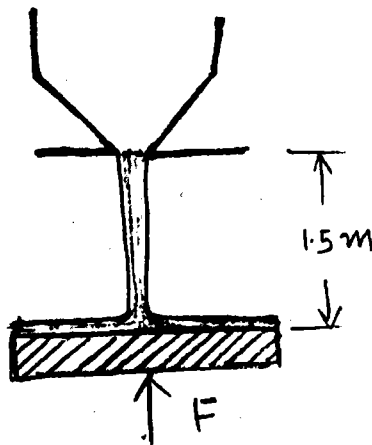

- (1) 0.314 N (2) 0.908 N (3) 1.816 N (4) 628 N
85. Velocity components in a flowfield are given by $u = 0$, $v = a(y^2 - z^2)$, $w = -2ayz$. Expressions for the stream function (Ψ) and velocity potential (Φ), respectively, are
- (1) $\Psi = ay^2z - \frac{az^3}{3} + \text{constant}$; Φ does not exist
 (2) $\Psi = ay^2z - \frac{az^3}{3} + \text{constant}$; $\Phi = -ayz^2 + \frac{ay^3}{3} + \text{constant}$
 (3) $\Psi = -ayz^2 + \frac{az^3}{3} + \text{constant}$; Φ does not exist
 (4) $\Psi = -ay^2z + \frac{az^3}{3} + \text{constant}$; $\Phi = ay^2z - \frac{ay^3}{3} + \text{constant}$

SOLID MECHANICS

86. The thin solid shaft of length L and radius r (shown in the Figure) is fixed at one end. A rigid rod is attached to this shaft at the other end. The rigid rod is subjected to a set of equal opposite forces P at its ends perpendicular to the axis of the shaft as shown. The rigidity modulus of the material of the shaft is given by G . Determine the maximum tensile stress at point 'A' on the surface of the shaft as shown in the Figure.

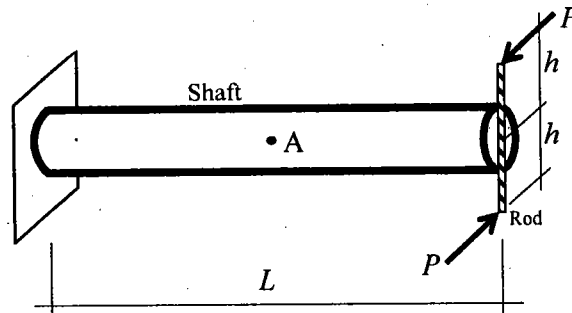

- (1) $\frac{Ph}{\pi r^3}$ (2) $\frac{4Ph}{\pi r^3}$ (3) $\frac{8PL}{\pi r^3}$ (4) $\frac{4Ph}{\pi r^2 L}$

87. A simply-supported concrete bridge girder has a span of 8 m . Under sunlight, the top surface of the girder heats up to $+40^\circ\text{C}$, but the bottom surface remains at $+25^\circ\text{C}$ (see Figure). The cross section of the girder is rectangular and of size $600\text{ mm} \times 800\text{ mm}$. The Modulus of Elasticity E and the coefficient of thermal expansion α of concrete are $25,000\text{ MPa}$ and $10 \times 10^{-6}/^\circ\text{C}$, respectively. Assume that (a) the girder remains uncracked under the differential loading due to temperature, and (b) the gradient of temperature is uniform across the depth of the girder. What is the maximum additional flexural normal stress in the girder?

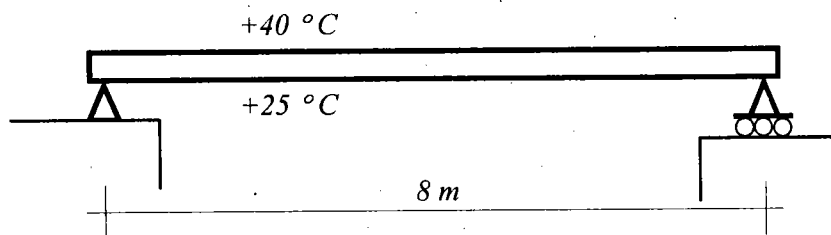

- (1) 0 MPa (2) 1.5 MPa (3) 3.0 MPa (4) 8.0 MPa

88. A two-bar prop is used to support an artifact in a Museum (see Figure); the bars are connected to each other by frictionless hinges. Both the bars are made of the same material (properties E and ν) and have negligible mass. The areas of cross-section of the two bars are A and $\sqrt{2}A$ as shown in the Figure. If the weight of the artifact supported is W , what is the elastic axial strain energy stored in the two bars together due to application of weight W ?

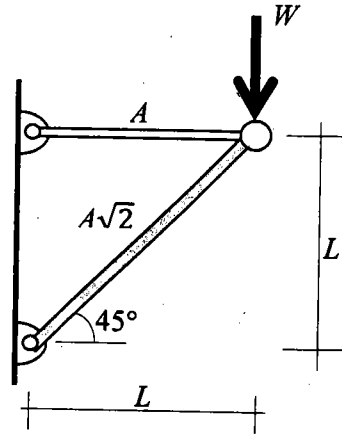

- (1) $\frac{W^2 L}{2EA}$ (2) $\frac{W^2 L}{EA}$ (3) $\frac{3W^2 L}{2EA}$ (4) $\frac{(1+2\sqrt{2})W^2 L}{2EA}$

89. Obtain the elastic flexural deflection Δ at the free end of the cantilever beam shown in the Figure subjected a concentrated load at a distance of L from the support. The beam cross-section has a moment of inertia of I . The material of the beam has Modulus of Elasticity E .

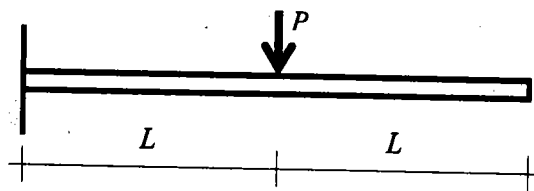

- (1) $\Delta = \frac{PL^3}{48EI}$ (2) $\Delta = \frac{PL^3}{2EI}$ (3) $\Delta = \frac{5PL^3}{6EI}$ (4) $\Delta = \frac{5PL^3}{3EI}$

90.

A beam with a cantilever overhang is loaded as shown in the Figure. What are the Shear Force and Bending Moment Diagrams?

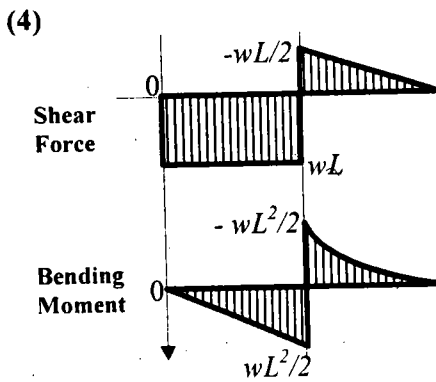
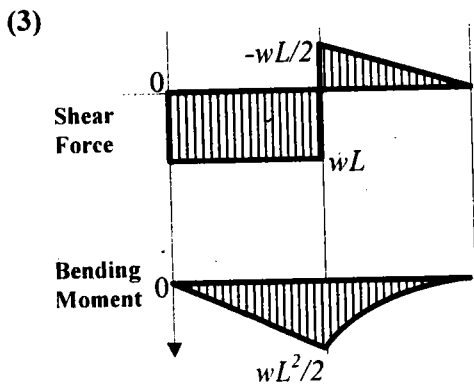
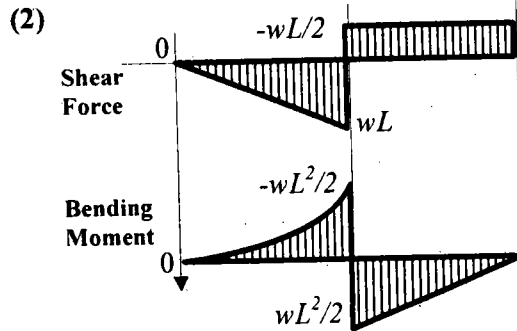
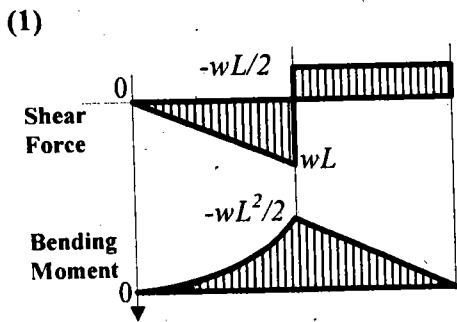
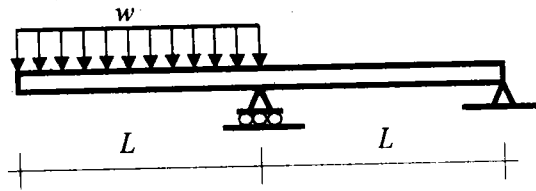

91.

A fixed-base portal frame has uniform cross-section of breadth b and depth h . A section of the portal frame is subjected to shear force V and bending moment $M (=Vh)$. What is the flexural normal stress at a height of $h/4$ from the top fibre of the section?

(1) $\frac{V}{bh}$

(2) $\frac{V}{2bh}$

(3) $\frac{V}{3bh}$

(4) $\frac{V}{4bh}$

92. An elastic spring of stiffness k is loaded with a weight W at its free end (See Figure). Two options are available for the method of application loading:

Option A : Slowly (almost statically)
 Option B : Suddenly (dynamically)

Assume there is no damping in the spring-mass system. What is the ratio of the maximum deflection Δ at the free end of the spring generated in Option B to that in Option A?

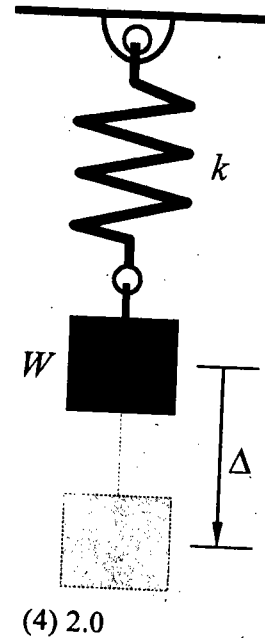

- (1) 0.5 (2) 1.0 (3) 1.5

(4) 2.0

93. An object made of elastic material (Modulus of Elasticity E and Poisson's Ratio μ) is restrained from moving in the x -direction by two rigid walls as shown in the Figure; it is free to move in the other two directions. A stress of σ is applied on it in the y -direction as shown. Find the relationship between the applied compressive stress σ and the compressive strain ϵ in the y -direction.

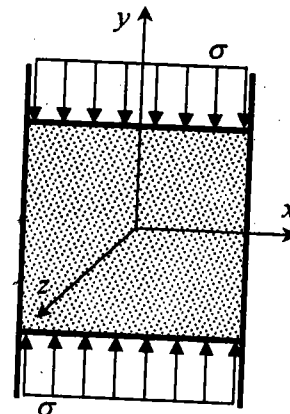

- (1) $\sigma = E\epsilon$ (2) $\sigma = \frac{E}{1+\mu}\epsilon$ (3) $\sigma = \frac{E}{1-\mu}\epsilon$ (4) $\sigma = \frac{E}{1-\mu^2}\epsilon$

94. A hand roller of mass m and diameter 500 mm is required to be moved to a higher ground level of step 30 mm as shown in the Figure. Two possibilities exist to take it to the higher ground level, namely (a) it can be *pushed* over to the higher level, or (b) it can be *pulled* to the higher level (See Figure). The coefficient of friction between the roller and the ground is 0.2 . Draw the free body diagram of the roller alone at the instant of roll over or pushover for the two cases.

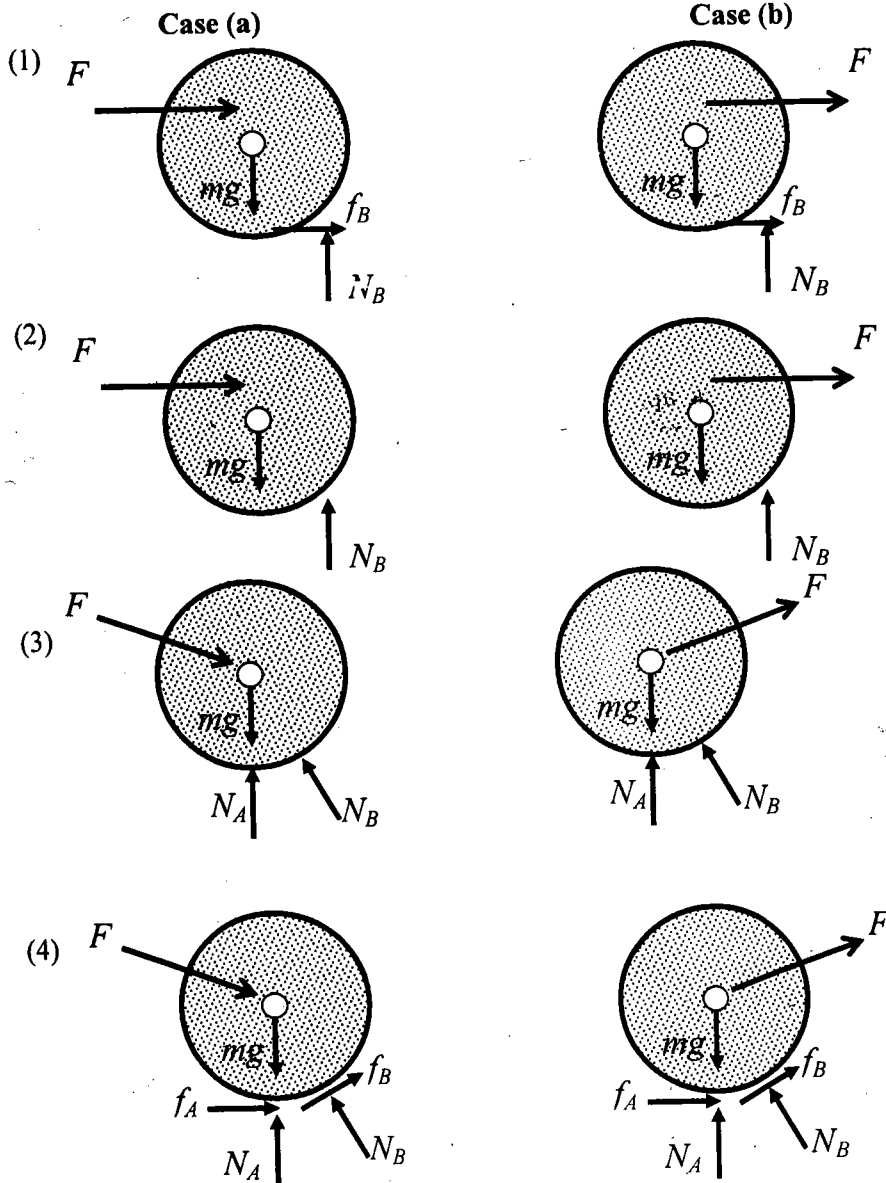
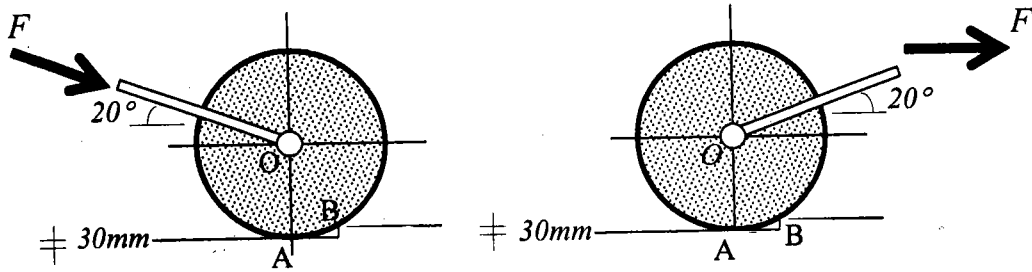

95. A cantilever beam is subjected to a combination of axial force, transverse forces and moment as shown in the Figure. The beam is sectioned at point A. Draw the Free Body Diagram of the right half of the beam.

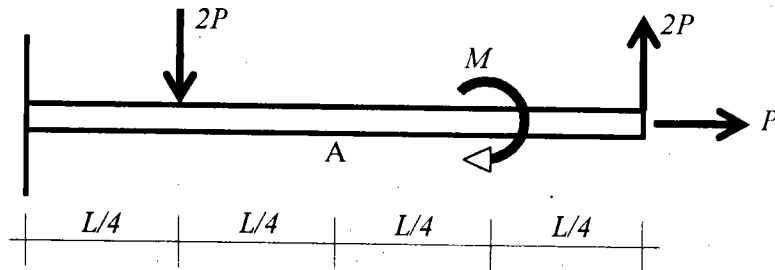

(1)

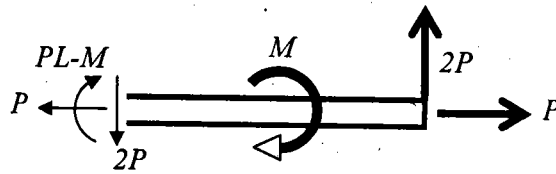

(2)

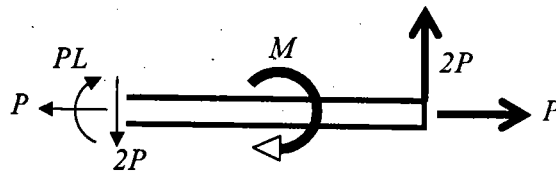

(3)

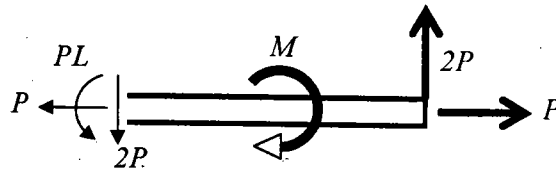

(4)

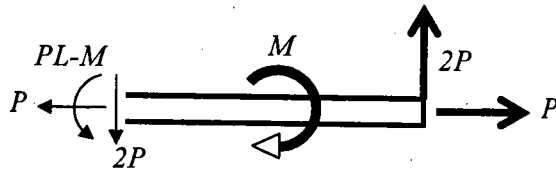

THERMODYNAMICS

96. A well-insulated rigid tank is connected through a valve to a main supply line which carries air at 0.8 MPa and 30°C. The tank is initially completely evacuated. The valve is now opened and air is allowed to flow into the tank until the tank pressure reaches 0.8 MPa, at which point the valve is closed. Kinetic and potential energy effects are negligibly small. The final temperature of air in the tank will be

(1) less than 30°C (2) equal to 30°C (3) greater than 30°C (4) a function of tank volume

97. A sealed rigid vessel having a volume of 2 m³ contains a saturated mixture of liquid and vapour of refrigerant R-134a at 10°C. The vessel is now heated to 50°C, and the process stops when the liquid phase just disappears completely.

R134a Properties: at 50°C, saturation pressure, $P_{\text{sat}} = 1318$ kPa; specific volume of saturated vapour, $v_g = 0.015$ m³/kg.

At 10°C, saturation pressure, $P_{\text{sat}} = 414.9$ kPa; specific volume of saturated liquid, $v_f = 0.0008$ m³/kg; specific volume of saturated vapour, $v_g = 0.05$ m³/kg.

The initial mass of the liquid (in kg) was

(1) 11.54 (2) 28.46 (3) 38.48 (4) 94.85

98. A coal-fired power plant, operating on a *simple ideal* Rankine cycle, has a boiler pressure of 32 bar and a condenser pressure of 0.75 bar. The exit state from the steam turbine is dry saturated vapour. Given saturated water properties:

Pressure (bar)	v_f (m ³ /kg)	h_f (kJ/kg)	h_g (kJ/kg)	s_f (kJ/kgK)	s_g (kJ/kgK)
0.75	0.001037	384.36	2662.96	1.2129	7.4563
32.0	0.001224	1025	2803	2.678	6.160

Superheat steam properties: at 32 bar & 592°C, $h_g = 3663$ kJ/kg, $s_g = 7.4563$ kJ/kgK.

The specific heat addition in the boiler (in kJ/kg) and the specific pump work input (in kJ/kg) would be

(1) 1778 and 3.24 (2) 2415.3 and 6.48
(3) 2638 and 641.64 (4) 3275.4 and 3.24

99. A frictionless piston-cylinder device contains 1 kg of a gas, having a specific gas constant of 0.5 kJ/kgK. Assume 1.5 to be the specific heat ratio of the gas. The piston is free to move. Heat is added to the gas until the temperature rises by 10°C. The amount of heat added (in kJ) is

(1) 1 (2) 10 (3) 15 (4) 283

100. Consider atmospheric air which is an air-water vapour mixture (considered to be an ideal gas mixture) at 100 kPa, at a dry bulb temperature of 15°C and 40% relative humidity. Water saturation pressure at 15°C = 1.705 kPa. R (specific gas constant) of water vapour = 0.461 kJ/kgK and R of air = 0.287 kJ/kgK. The humidity ratio (in gm of water/kg of dry air) is

(1) 4.275 (2) 6.867 (3) 10.688 (4) 17.168

101. An inventor claims to have developed a cyclic heat conversion system (HE) which simultaneously produces power, refrigeration and heating output by interacting with three thermal reservoirs as shown in the figure. The system proposed is

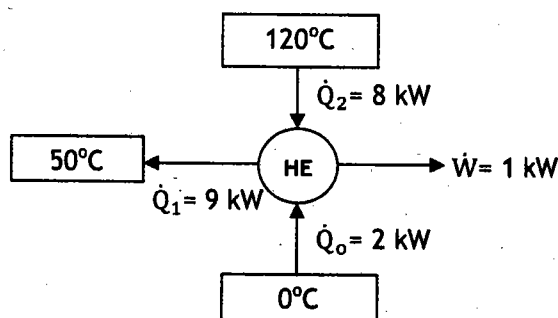

- (1) not feasible as it violates first law of thermodynamics
 (2) not feasible as it violates second law of thermodynamics
 (3) feasible and it is a reversible system
 (4) feasible and it is an irreversible system
102. An evacuated rigid tank is filled up to certain pressure from a pressurized gas supply line. Consider two cases both following the ideal gas model. In the first case (case 1) the tank is insulated and in the second case (case 2) heat is lost to the surroundings from the gas in the tank. Ignore kinetic and potential energy effects. Which of the following statements is correct about the two cases regarding final mass of gas in the tank?
- (1) Final mass in case 1 is equal to that in case 2
 (2) Final mass in case 1 is less than that in case 2
 (3) Final mass in case 1 is greater than that in case 2
 (4) Comparison between final mass in case and case 2 is not possible from given data
103. A steady flow adiabatic turbine operates with air (assumed to be an ideal gas) entering at 500 kPa, 425 K and 150 m/s and leaving at 100 kPa, 325 K and 50 m/s. Assume T_o (surrounding temperature) = 27°C. Also assume, for air, specific heat $c_p = 1.0$ kJ/kgK and specific gas constant $R = 0.3$ kJ/kgK. The maximum work (in kJ/kg) that can be produced by this turbine is

(1) 110.0 (2) 164.0 (3) 174.4 (3) 348.8

104. Lenoir cycle, which approximates the operation of a pulse jet, is shown in the figure on the pressure-specific volume plane. The processes are as follows:

- i) 1-2, isochoric, heat addition of 230 kJ/kg;
- ii) 2-3, adiabatic expansion, change in internal energy = -75 kJ/kg;
- iii) 3-1, isobaric compression, heat rejection of 190 kJ/kg.

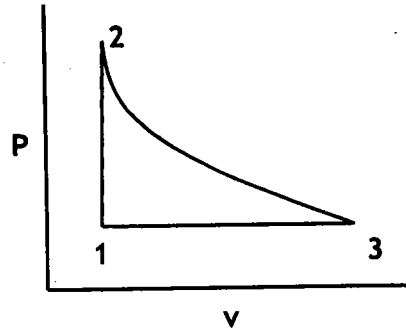

The net work output (kJ/kg) of the cycle and change in internal energy (kJ/kg) during process 3-1 are

- (1) -40 and -155 (2) 40 and -155 (3) 40 and 155 (4) -40 and 155
105. The slope of saturation pressure-temperature curve (P_{sat} vs. T) of ammonia at 50°C is $50 \text{ kN/m}^2\text{K}$. The specific volume of saturated ammonia vapour at 50°C is $0.0634 \text{ m}^3/\text{kg}$, while the specific volume of saturated liquid is negligible compared to that of the vapour. The enthalpy of vaporization (in kJ/kg) of ammonia at 50°C , using Clapeyron equation, is

- (1) 15.85 (2) 157.5 (3) 1023.9 (4) 39680

ELECTRONICS

106. Assuming ideal OPAMPs, the output voltage V_0 in the circuit shown below will be:

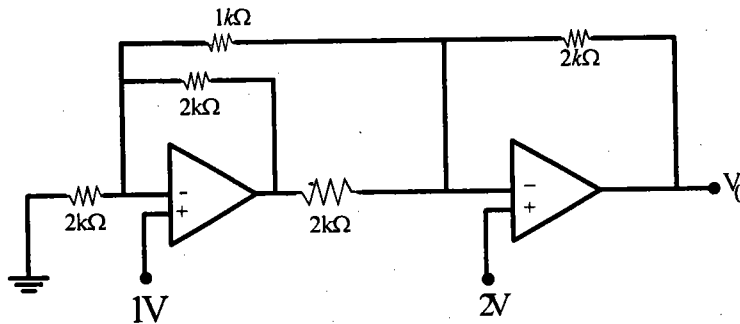

- (1) 2V (2) 4V (3) 6V (4) 8V
107. An amplifier has a mid-band gain of 100, a lower 3-dB frequency of 0.1 Hz and an upper 3-dB frequency of 120 Hz. What is the range of frequency for which the gain will be at least 99?
- (1) 0.3 – 8 Hz (2) 0.7 – 16.97 Hz (3) 1 – 10 Hz (4) 0.6 – 12 Hz

108. In the circuit shown below, what will be the value of R for V_0 to become zero?
Assume the following:

Diode conduction drop (V_D) = 0.7 V

Transistor : $V_{BE} = 0.7$ V and h_{FE} is very large.

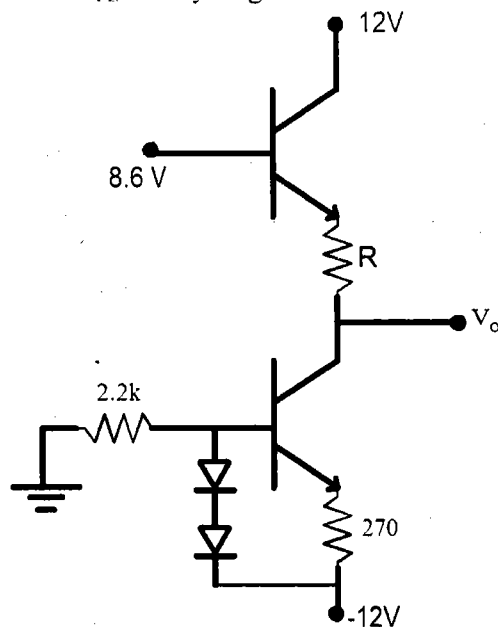

- (1) 2.06 k Ω (2) 1.56 k Ω (3) 3.6 k Ω (4) 2.63 k Ω
109. Consider a fast-food restaurant in which a customer is nine times as likely to order a chicken burger as a fish sandwich. Suppose that each customer orders either one chicken burger or one fish sandwich. If the restaurant serves an average of eight customers per minute, the information rate of food order is
- (1) 0.0625 bit/sec (2) 0.55 bit/sec (3) 3.25 bit/sec (4) 1 bit/sec
110. The ratio of total average power to the average carrier power of sinusoidal amplitude modulation is 1.18. The rms value of antenna current for such transmission is 10.86 ampere. The corresponding unmodulated current in ampere is given by
- (1) 15 (2) 8 (3) 10 (4) 20

111. An LTI system is characterized by the difference equation

$$y[n] - 0.2y[n-1] + 0.01y[n-2] = x[n]$$

The impulse response of the system is

- (1) $n(0.1)^n u(n)$ (2) $(n+1)(0.1)^{n+1} u(n)$
 (3) $n(0.1)^{n+1} u(n+1)$ (4) $(n+1)(0.1)^n u(n+1)$

112. The inverse z-transform of $z^{-2} \log(1 - 2z^{-1})$ with $ROC = (|z| > |2|)$ is

- (1) $\frac{2^n}{(n-2)} u(n-2)$ (2) $\frac{2^n}{n} u(n)$
 (3) $\frac{-0.25}{(n-2)} 2^n u(n-2)$ (4) $\frac{-0.25}{n} 2^n u(n)$

113. A random signal is generated by passing white noise signal through an ideal LTI system with transfer function e^{-5s} . If the autocorrelation of input random signal is $R(\tau) = 3e^{-2|\tau|}$, the power spectral density of the output signal is

- (1) $12e^{-j5\omega}$ (2) $12e^{-j10\omega}$ (3) $\frac{12}{\omega^2 + 4}$ (4) $\frac{12e^{-10\omega}}{\omega^2 + 4}$

114. A Boolean algebraic expression F is given as:

$$F = (A + B)(A + \bar{A} + \bar{B})C + \bar{A}(B + \bar{C}) + \bar{A}B + ABC$$

where A , B and C are logical variables. The most simplified expression for F is:

- (1) $C(A + B) + \bar{A}(B + \bar{C})$ (2) $(C + AB)(A + B\bar{C})$
 (3) $C\bar{A} + A\bar{B}$ (4) $CAB + \bar{A}B + \bar{B}\bar{C}$

115. The analog output voltage of a R-2R ladder network based 6-bit DAC with a reference voltage of 5 volts and for a digital input of 011100 is

- (1) 1.0937 V (2) 2.1875 V (3) 0.5468 V (4) 4.3750 V

रफ़ कार्य/ROUGH WORK

रफ़ कार्य/ROUGH WORK

रफ़ कार्य/ROUGH WORK

रफ़ कार्य/ROUGH WORK

रफ़ कार्य/ROUGH WORK

रफ़ कार्य/ROUGH WORK

Roll Number

Booklet Code

Medium

Subject Code

Centre Code

000000

A

E

6

00

SIDE - 2

1	1	1	1	1	1
2	2	2	2	2	2
3	3	3	3	3	3
4	4	4	4	4	4
5	5	5	5	5	5
6	6	6	6	6	6
7	7	7	7	7	7
8	8	8	8	8	8
9	9	9	9	9	9
0	0	0	0	0	0

B

C

1

2

3

4

5

1

2

3

4

5

6

7

8

9

0

INSTRUCTION FOR INVIGILATOR

Check Roll Number, Booklet Code, Subject Code, Centre Code & Signature of Candidate before signing.

Signature of Invigilator

PART 'A'

Q.No.	ANSWER			
	1	2	3	4
1	<input type="radio"/>	<input type="radio"/>	<input type="radio"/>	<input checked="" type="radio"/>
2	<input type="radio"/>	<input type="radio"/>	<input checked="" type="radio"/>	<input type="radio"/>
3	<input type="radio"/>	<input type="radio"/>	<input checked="" type="radio"/>	<input type="radio"/>
4	<input checked="" type="radio"/>	<input type="radio"/>	<input type="radio"/>	<input type="radio"/>
5	<input type="radio"/>	<input checked="" type="radio"/>	<input type="radio"/>	<input type="radio"/>
6	<input type="radio"/>	<input type="radio"/>	<input type="radio"/>	<input checked="" type="radio"/>
7	<input checked="" type="radio"/>	<input type="radio"/>	<input type="radio"/>	<input type="radio"/>
8	<input type="radio"/>	<input type="radio"/>	<input type="radio"/>	<input checked="" type="radio"/>
9	<input type="radio"/>	<input type="radio"/>	<input checked="" type="radio"/>	<input type="radio"/>
10	<input checked="" type="radio"/>	<input type="radio"/>	<input type="radio"/>	<input type="radio"/>
11	<input type="radio"/>	<input checked="" type="radio"/>	<input type="radio"/>	<input type="radio"/>
12	<input type="radio"/>	<input type="radio"/>	<input type="radio"/>	<input checked="" type="radio"/>
13	<input type="radio"/>	<input type="radio"/>	<input checked="" type="radio"/>	<input type="radio"/>
14	<input type="radio"/>	<input type="radio"/>	<input checked="" type="radio"/>	<input type="radio"/>
15	<input checked="" type="radio"/>	<input type="radio"/>	<input type="radio"/>	<input type="radio"/>
16	<input checked="" type="radio"/>	<input type="radio"/>	<input type="radio"/>	<input type="radio"/>
17	<input type="radio"/>	<input type="radio"/>	<input checked="" type="radio"/>	<input type="radio"/>
18	<input checked="" type="radio"/>	<input type="radio"/>	<input type="radio"/>	<input type="radio"/>
19	<input type="radio"/>	<input checked="" type="radio"/>	<input type="radio"/>	<input type="radio"/>
20	<input type="radio"/>	<input type="radio"/>	<input checked="" type="radio"/>	<input type="radio"/>

Q.No.	ANSWER			
	1	2	3	4
21	<input type="radio"/>	<input type="radio"/>	<input type="radio"/>	<input checked="" type="radio"/>
22	<input type="radio"/>	<input checked="" type="radio"/>	<input type="radio"/>	<input type="radio"/>
23	<input type="radio"/>	<input checked="" type="radio"/>	<input type="radio"/>	<input type="radio"/>
24	<input type="radio"/>	<input type="radio"/>	<input checked="" type="radio"/>	<input type="radio"/>
25	<input type="radio"/>	<input type="radio"/>	<input checked="" type="radio"/>	<input type="radio"/>
26	<input checked="" type="radio"/>	<input type="radio"/>	<input type="radio"/>	<input type="radio"/>
27	<input type="radio"/>	<input type="radio"/>	<input checked="" type="radio"/>	<input type="radio"/>
28	<input type="radio"/>	<input type="radio"/>	<input checked="" type="radio"/>	<input type="radio"/>
29	<input type="radio"/>	<input checked="" type="radio"/>	<input type="radio"/>	<input type="radio"/>
30	<input type="radio"/>	<input type="radio"/>	<input checked="" type="radio"/>	<input type="radio"/>
31	<input type="radio"/>	<input checked="" type="radio"/>	<input type="radio"/>	<input type="radio"/>
32	<input checked="" type="radio"/>	<input type="radio"/>	<input type="radio"/>	<input type="radio"/>
33	<input type="radio"/>	<input type="radio"/>	<input checked="" type="radio"/>	<input type="radio"/>
34	<input type="radio"/>	<input type="radio"/>	<input checked="" type="radio"/>	<input type="radio"/>

ANSWER COLUMNS

Q.No.	ANSWER			
	1	2	3	4
35	<input type="radio"/>	<input type="radio"/>	<input type="radio"/>	<input checked="" type="radio"/>
36	<input type="radio"/>	<input checked="" type="radio"/>	<input type="radio"/>	<input type="radio"/>
37	<input type="radio"/>	<input checked="" type="radio"/>	<input type="radio"/>	<input type="radio"/>
38	<input type="radio"/>	<input type="radio"/>	<input checked="" type="radio"/>	<input type="radio"/>
39	<input type="radio"/>	<input checked="" type="radio"/>	<input type="radio"/>	<input type="radio"/>
40	<input checked="" type="radio"/>	<input type="radio"/>	<input type="radio"/>	<input type="radio"/>
41	<input type="radio"/>	<input type="radio"/>	<input type="radio"/>	<input checked="" type="radio"/>
42	<input type="radio"/>	<input checked="" type="radio"/>	<input type="radio"/>	<input type="radio"/>
43	<input checked="" type="radio"/>	<input type="radio"/>	<input type="radio"/>	<input type="radio"/>
44	<input type="radio"/>	<input type="radio"/>	<input type="radio"/>	<input checked="" type="radio"/>
45	<input checked="" type="radio"/>	<input type="radio"/>	<input type="radio"/>	<input type="radio"/>

PART 'C'

46	<input type="radio"/>	<input type="radio"/>	<input type="radio"/>	<input checked="" type="radio"/>
47	<input type="radio"/>	<input checked="" type="radio"/>	<input type="radio"/>	<input type="radio"/>
48	<input type="radio"/>	<input type="radio"/>	<input checked="" type="radio"/>	<input type="radio"/>
49	<input type="radio"/>	<input type="radio"/>	<input type="radio"/>	<input checked="" type="radio"/>
50	<input type="radio"/>	<input checked="" type="radio"/>	<input type="radio"/>	<input type="radio"/>
51	<input type="radio"/>	<input type="radio"/>	<input checked="" type="radio"/>	<input type="radio"/>
52	<input type="radio"/>	<input checked="" type="radio"/>	<input type="radio"/>	<input type="radio"/>
53	<input checked="" type="radio"/>	<input type="radio"/>	<input type="radio"/>	<input type="radio"/>
54	<input checked="" type="radio"/>	<input type="radio"/>	<input type="radio"/>	<input type="radio"/>
55	<input type="radio"/>	<input checked="" type="radio"/>	<input type="radio"/>	<input type="radio"/>
56	<input type="radio"/>	<input checked="" type="radio"/>	<input type="radio"/>	<input type="radio"/>
57	<input checked="" type="radio"/>	<input type="radio"/>	<input type="radio"/>	<input type="radio"/>
58	<input type="radio"/>	<input type="radio"/>	<input type="radio"/>	<input checked="" type="radio"/>
59	<input type="radio"/>	<input type="radio"/>	<input checked="" type="radio"/>	<input type="radio"/>
60	<input type="radio"/>	<input checked="" type="radio"/>	<input type="radio"/>	<input type="radio"/>
61	<input checked="" type="radio"/>	<input type="radio"/>	<input type="radio"/>	<input type="radio"/>
62	<input type="radio"/>	<input checked="" type="radio"/>	<input type="radio"/>	<input type="radio"/>
63	<input type="radio"/>	<input type="radio"/>	<input checked="" type="radio"/>	<input type="radio"/>
64	<input type="radio"/>	<input type="radio"/>	<input checked="" type="radio"/>	<input type="radio"/>
65	<input type="radio"/>	<input type="radio"/>	<input type="radio"/>	<input checked="" type="radio"/>
66	<input type="radio"/>	<input checked="" type="radio"/>	<input type="radio"/>	<input type="radio"/>
67	<input type="radio"/>	<input checked="" type="radio"/>	<input type="radio"/>	<input type="radio"/>
68	<input type="radio"/>	<input type="radio"/>	<input type="radio"/>	<input checked="" type="radio"/>

Q.No.	ANSWER			
	1	2	3	4
69	<input checked="" type="radio"/>	<input type="radio"/>	<input type="radio"/>	<input type="radio"/>
70	<input type="radio"/>	<input checked="" type="radio"/>	<input type="radio"/>	<input type="radio"/>
71	<input type="radio"/>	<input checked="" type="radio"/>	<input type="radio"/>	<input type="radio"/>
72	<input type="radio"/>	<input checked="" type="radio"/>	<input type="radio"/>	<input type="radio"/>
73	<input type="radio"/>	<input type="radio"/>	<input checked="" type="radio"/>	<input type="radio"/>
74	<input type="radio"/>	<input checked="" type="radio"/>	<input type="radio"/>	<input type="radio"/>
75	<input type="radio"/>	<input type="radio"/>	<input checked="" type="radio"/>	<input type="radio"/>
76	<input type="radio"/>	<input type="radio"/>	<input type="radio"/>	<input checked="" type="radio"/>
77	<input type="radio"/>	<input type="radio"/>	<input type="radio"/>	<input checked="" type="radio"/>
78	<input type="radio"/>	<input type="radio"/>	<input checked="" type="radio"/>	<input type="radio"/>
79	<input type="radio"/>	<input type="radio"/>	<input type="radio"/>	<input checked="" type="radio"/>
80	<input type="radio"/>	<input type="radio"/>	<input checked="" type="radio"/>	<input type="radio"/>
81	<input type="radio"/>	<input checked="" type="radio"/>	<input type="radio"/>	<input type="radio"/>
82	<input type="radio"/>	<input type="radio"/>	<input checked="" type="radio"/>	<input type="radio"/>
83	<input checked="" type="radio"/>	<input type="radio"/>	<input type="radio"/>	<input type="radio"/>
84	<input type="radio"/>	<input checked="" type="radio"/>	<input type="radio"/>	<input type="radio"/>
85	<input type="radio"/>	<input checked="" type="radio"/>	<input type="radio"/>	<input type="radio"/>
86	<input type="radio"/>	<input checked="" type="radio"/>	<input type="radio"/>	<input type="radio"/>
87	<input checked="" type="radio"/>	<input type="radio"/>	<input type="radio"/>	<input type="radio"/>
88	<input type="radio"/>	<input type="radio"/>	<input checked="" type="radio"/>	<input type="radio"/>
89	<input type="radio"/>	<input type="radio"/>	<input checked="" type="radio"/>	<input type="radio"/>
90	<input checked="" type="radio"/>	<input type="radio"/>	<input type="radio"/>	<input type="radio"/>
91	<input type="radio"/>	<input type="radio"/>	<input checked="" type="radio"/>	<input type="radio"/>
92	<input type="radio"/>	<input type="radio"/>	<input type="radio"/>	<input checked="" type="radio"/>
93	<input type="radio"/>	<input type="radio"/>	<input type="radio"/>	<input checked="" type="radio"/>
94	<input type="radio"/>	<input checked="" type="radio"/>	<input type="radio"/>	<input type="radio"/>
95	<input checked="" type="radio"/>	<input type="radio"/>	<input type="radio"/>	<input type="radio"/>
96	<input type="radio"/>	<input type="radio"/>	<input checked="" type="radio"/>	<input type="radio"/>
97	<input type="radio"/>	<input type="radio"/>	<input type="radio"/>	<input checked="" type="radio"/>
98	<input type="radio"/>	<input type="radio"/>	<input type="radio"/>	<input checked="" type="radio"/>
99	<input type="radio"/>	<input type="radio"/>	<input type="radio"/>	<input checked="" type="radio"/>
100	<input checked="" type="radio"/>	<input type="radio"/>	<input type="radio"/>	<input type="radio"/>
101	<input type="radio"/>	<input type="radio"/>	<input type="radio"/>	<input checked="" type="radio"/>
102	<input type="radio"/>	<input checked="" type="radio"/>	<input type="radio"/>	<input type="radio"/>
103	<input type="radio"/>	<input type="radio"/>	<input checked="" type="radio"/>	<input type="radio"/>

Q.No.	ANSWER			
	1	2	3	4
104	<input type="radio"/>	<input checked="" type="radio"/>	<input type="radio"/>	<input type="radio"/>
105	<input type="radio"/>	<input type="radio"/>	<input checked="" type="radio"/>	<input type="radio"/>
106	<input type="radio"/>	<input type="radio"/>	<input checked="" type="radio"/>	<input type="radio"/>
107	<input type="radio"/>	<input checked="" type="radio"/>	<input type="radio"/>	<input type="radio"/>
108	<input type="radio"/>	<input type="radio"/>	<input type="radio"/>	<input checked="" type="radio"/>
109	<input checked="" type="radio"/>	<input type="radio"/>	<input type="radio"/>	<input type="radio"/>
110	<input type="radio"/>	<input type="radio"/>	<input checked="" type="radio"/>	<input type="radio"/>
111	<input type="radio"/>	<input type="radio"/>	<input type="radio"/>	<input checked="" type="radio"/>
112	<input type="radio"/>	<input type="radio"/>	<input checked="" type="radio"/>	<input type="radio"/>
113	<input type="radio"/>	<input type="radio"/>	<input checked="" type="radio"/>	<input type="radio"/>
114	<input checked="" type="radio"/>	<input type="radio"/>	<input type="radio"/>	<input type="radio"/>
115	<input type="radio"/>	<input checked="" type="radio"/>	<input type="radio"/>	<input type="radio"/>



Note: Roll Number, Subject Code & Centre Code should be filled in the boxes using the pattern given as:

000000