

GENERAL PRINCIPLES OF METALLURGY

Topic: 3

Process of molten electrolysis of Al, Mg and Na

LONG ANSWER QUESTIONS

1. Explain the extraction of Aluminium from its ore.

Extraction of Aluminium from its Ore

Introduction to Extraction of Metals from Ores:

The process of extraction of metals from their ores is called metallurgy. Ores are generally associated with non metallic impurities of earthy and rocky material. Such materials are called gangue or matrix. The process of extraction depends upon the nature of impurities present in the ore. Common steps involved for extraction of metals are as follows:

- (i) Crushing and grinding
- (ii) Concentration of ore
- (iii) Extracting metal from ore
- (iv) Purification of metal

Extraction of Aluminium from its Ore:

Aluminium was an expensive and of little use for a long time. Its use increased in 1886, when Charles independently found a way to obtain the metal by electrolysis. Aluminium is most abundant metal on the earth's crust. The percentage of this metal in earth's crust is about 32% of total metals and 8.3% of total elements.

Extraction of Aluminium:

Major ore of aluminium is bauxite ($\text{Al}_2\text{O}_3 \cdot 2\text{H}_2\text{O}$). It is an oxide of aluminium. Though, aluminium oxide can be reduced by chemical methods, but it is extracted from its ore by electrolysis, because it is highly reactive metal.

Steps of Extraction of Aluminium from its Ore:

The extraction of aluminium involves following steps:

(i) Purification: Bauxite ore contains lot of impurities which can be removed by treating it chemically. The sequence of its purification is shown in the flow chart given below:

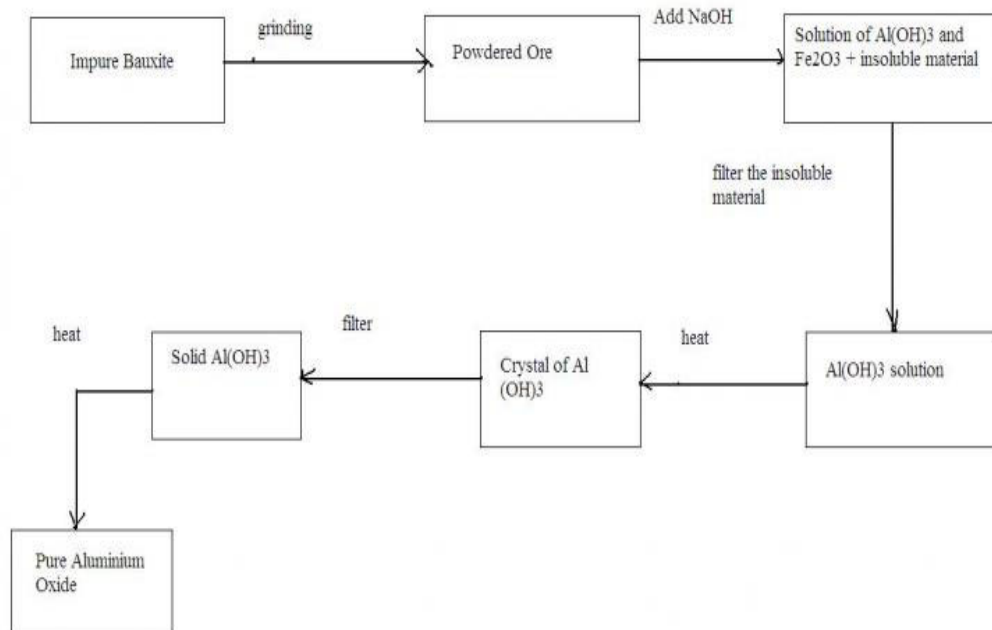

Detailed Description of Flowchart:

1. Bauxite ore is crushed.
2. It is then treated with sodium hydroxide (NaOH). It results in the formation of Al(OH)_3 , Fe_2O_3 and some insoluble material.



3. Iron oxide does not dissolve in NaOH and thus the products are filtered to get Al(OH)_3 .
4. Al(OH)_3 is heated and it is decomposed into Al_2O_3 and H_2O .

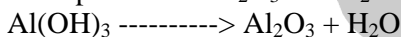

5. Hence, pure aluminium oxide Al_2O_3 is obtained.

Electrolysis Method

In this process, pure Al_2O_3 is added in an iron tank. In this tank, cryolite (Na_2AlF_6) and some fluorspar (CaF_2) is also added to reduce the melting point of Al_2O_3 . It also increases the conductivity and helps in breaking Al_2O_3 to form aluminium ions (Al^{+3}) and oxide ions (O^{-2}). Al^{+3} ions will move towards cathode and O^{-2} ions will move towards anode, where they are reduced and oxidised respectively into aluminium (Al) and oxygen (O_2).

The reaction taking place at cathode and anode are as follows:-

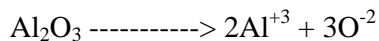

On Cathode: $2\text{Al}^{+3} + 6\text{e}^{-1} \longrightarrow 2\text{Al (metal)}$

On Anode: $6\text{O}^{-2} \longrightarrow 3\text{O}_2 + 12\text{e}^{-1}$

Aluminium obtained from above process is 99% pure, which is further purified by using electrolytic method.

2. Explain the methods of purification of metals.

Ans: Refining of Metals

The metals so extracted are further refined by suitable methods. The electrolytic method is the most suitable method for refining the non-ferrous metals. The metals produced by any method given above are not very pure. These need further refining. This can be done by any of the following methods:

Liquation method:

This method is used when the melting temperature of the metal is lower than that of the impurity and the impurities are not miscible with the metal. Metals like Bi, Sn, Pb, Hg etc., are purified by this method. The sloping floor of a reverberatory furnace is used to melt crude metal, when the pure metal flows down, the impurities are left behind.

Distillation

When metals have low boiling points e.g., mercury, zinc, cadmium etc., most of the impurities can be separated by distillation. Their vapours, on condensation in a suitable condenser give the pure metal.

Poling

Oxide impurity of impure metals can be purified by this method. Poles of green wood are used to stir the molten crude metal sample. The hydrocarbon organic matter in the poles acts as a reducing agent and reduces the oxide impurities. This method is used for refining copper.

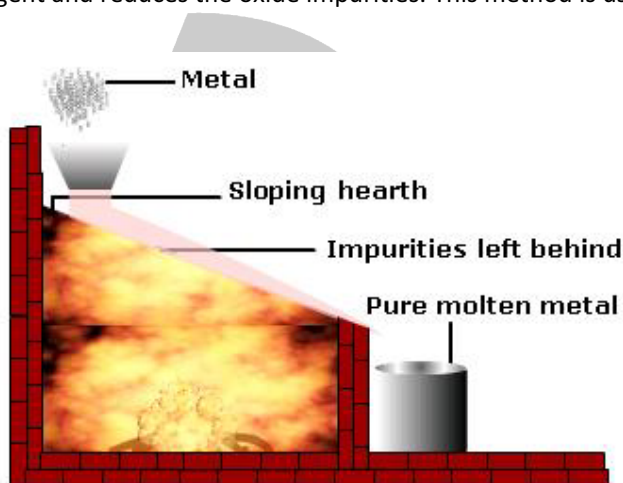

The Liquation method

Oxidation or cupellation

Impurities that can be oxidised to volatile products can be removed by oxidation. For example, the impurity of lead from silver is removed when lead is oxidized and led away by a current of air. Shining silver is left behind.

Molten pig iron is also purified by this technique in a Bessemer converter. The impurities in the form of volatile oxides, escape out.

Electrolytic method

A large number of metals e.g., copper, silver, gold, nickel etc. are refined by this method. In an electrolytic cell the impure metal is made anode and a thin strip of pure metal is made cathode. A solution of a suitable salt of the concerned metal is used to fill the electrolytic cell. On passing electricity, the anode undergoes dissolution while the pure metal gets deposited at

cathode. Insoluble impurities fall below the anode in the form of anode

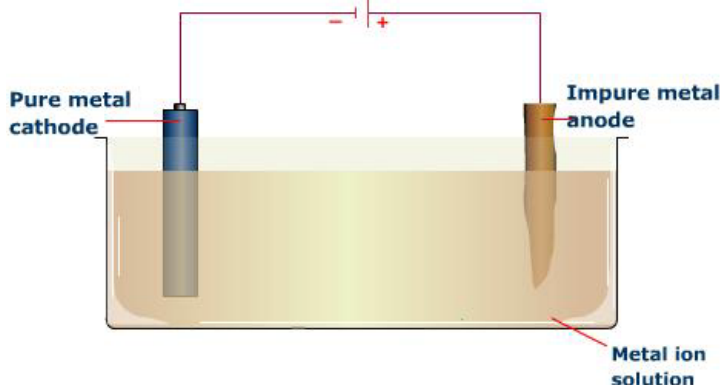

mud.

Zone refining method

When metals are required in an ultra pure state, the zone refining method is used. The principle employed states that the impurities, which lower the melting point of a metal remain preferentially dissolved in the liquid phase and purer metal will emerge in the solid phase.

In actual practice, a cylinder of impure metal is kept in a tubular furnace and the heater is made to move in one direction at a very slow speed. The solid material crystallizes as the heater moves along the tube, and the advancing zone contains liquid with higher impurity content. The process is repeated a number of times till the desired level of purity is obtained.

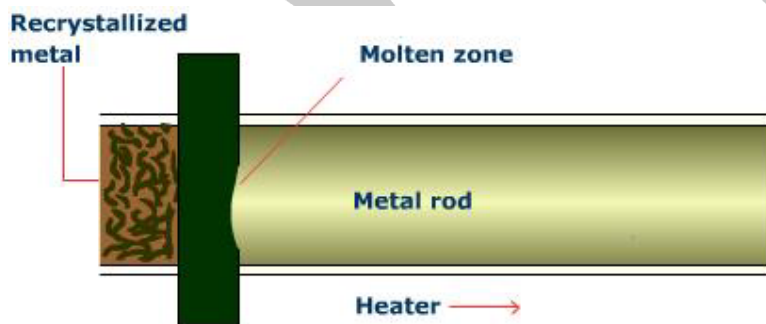

The Zone refining method

Van Arkel method

In the Van Arkel method impure metal is first converted into one of its unstable compounds. Heating the unstable compound of the metal at higher temperatures, decomposes it to give pure metal. For example, pure titanium can be obtained from impure titanium by converting it into tetraiodide, and then decomposing this tetraiodide to pure Ti.

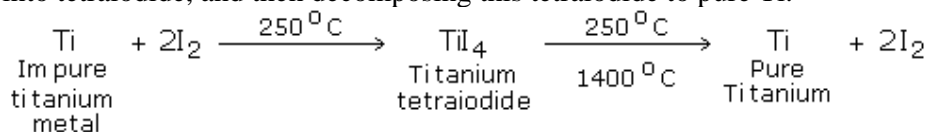

3. Mention any three minerals of Al. How is the ore purified?

Metallurgy of Aluminum

Common Name	Chemical Name	Formula
Bauxite	Hydrated aluminium oxide	$\text{Al}_2\text{O}_3 \cdot 2\text{H}_2\text{O}$
Cryolite	Sodium aluminum fluoride	Na_3AlF_6
Corundum	Aluminium Oxide	Al_2O_3

Pure aluminium is a silvery-white metal with many desirable characteristics. It is light, nontoxic (as the metal), nonmagnetic and non sparking. Pure aluminium is soft and lacks strength, but alloys with small amounts of copper, magnesium, silicon, manganese, and other elements have very useful properties. ~Aluminium is the third most abundant element in the Earth's crust after oxygen and silicon

Extraction of Aluminium

Aluminum is extracted from its oxide ore "Bauxite". The extraction of aluminum involves the following steps.

- Purification of Bauxite
- Electrolysis of Alumina
- Refining

Purification of Bauxite to Alumina

Bauxite contains two main impurities Fe_2O_3 and SiO_2 . These impurities must be removed in order to get good quality aluminum. These impurities make the aluminum brittle and liable to corrosion. Depending upon the nature of impurity present in bauxite, any one of the following methods can be used for the purification of bauxite.

Bayer's Process

Bayer's process involves concentration and dehydration of bauxite to alumina (Al_2O_3).

Treatment with NaOH

Bauxite is treated with hot, concentrated NaOH solution.

Aluminium oxide reacts with NaOH forming an aqueous solution of sodium aluminate. The impurities do not react.



On filtration, impurities are separated from the sodium aluminate solution.

Treatment with HCl

The filtrate containing sodium aluminate is acidified with hydrochloric acid to form a precipitate of aluminium hydroxide.

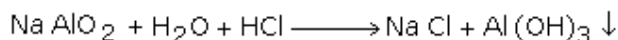

On filtration sodium chloride solution is obtained as a filtrate and is discarded. The pure aluminium hydroxide obtained as a gel is collected.

Action of Heat on $\text{Al}(\text{OH})_3$

The precipitate of $\text{Al}(\text{OH})_3$ is heated to a high temperature to obtain pure alumina.

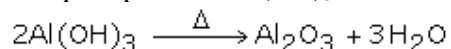

Thus, pure alumina is obtained from bauxite.

Hall's Process

In this process, the pure alumina (Al_2O_3) obtained from Bayer's process is electrolytically reduced to aluminium.



An electrolytic cell used is called the Hall's cell.

The Hall's cell is a steel tank lined inside with a layer of graphite which is made the cathode. The electrolyte consists of a mixture of fused (molten) alumina and cryolite. Cryolite is a flux and helps in lowering the melting point of alumina. A series of graphite rods dipped into the electrolyte serve as the anode.

When electricity is passed through the cell, the molten alumina dissociates forming Al^{3+} and O^{2-} ions,

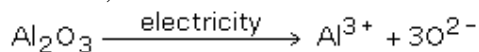

The Al^{3+} ions capture electrons of the cathode and get deposited at the bottom of the tank as molten aluminium.

The O^{2-} ions lose electrons to the anode and release oxygen gas. Some amount of carbon dioxide and carbon monoxide are also released, due to the reaction of oxygen atoms with the graphite anode.

Ionic Equations

At Cathode	At anode
Gain of electrons (reduction)	Loss of electrons (oxidation)
$\text{Al}^{3+} + 3\text{e}^- \longrightarrow \text{Al}$	$\text{O}^{2-} - 2\text{e}^- \longrightarrow \text{O}$
	$\text{O} + \text{O} \longrightarrow \text{O}_2 \uparrow$
	$\text{C} + \text{O} \longrightarrow \text{CO}_2$

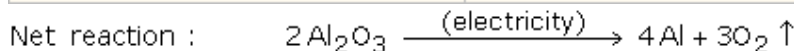

The molten aluminium thus collected is removed from an outlet at the bottom of the cell.

4. Explain the metallurgy of Aluminium.

Extraction of Aluminium

Pure Aluminium metal is extracted from bauxite in a three-stage process.

- Purification of Bauxite (Bayers Process) to obtain pure Alumina.
- Electrolysis of pure Alumina in molten cryolite (Na_3AlF_6) (Halls process).
- Refining of Aluminium (Hoopes process).

Purification of bauxite

Bauxite contains silicon dioxide (SiO_2), iron oxides and titanium(IV) oxide as impurities. The bauxite ore is digested with a concentrated solution of sodium hydroxide at 473-523 K and 35-36 bar pressure. Aluminium oxide and silica dissolve to form sodium aluminate and sodium silicate respectively leaving behind iron oxide and TiO_2 , which are filtered off.

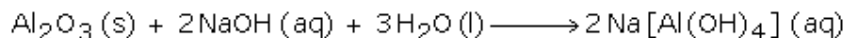

The filtrate containing sodium aluminate and sodium silicate is diluted and seeded with freshly precipitated aluminium hydroxide, which induces the precipitation of aluminium hydroxide leaving behind sodium silicate in solution.

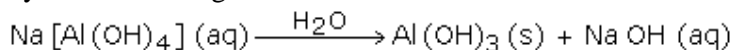

The aluminium hydroxide is filtered dried and calcined at 1473 K to yield pure alumina.

Electrolysis of pure alumina (Hall-Heroult process)

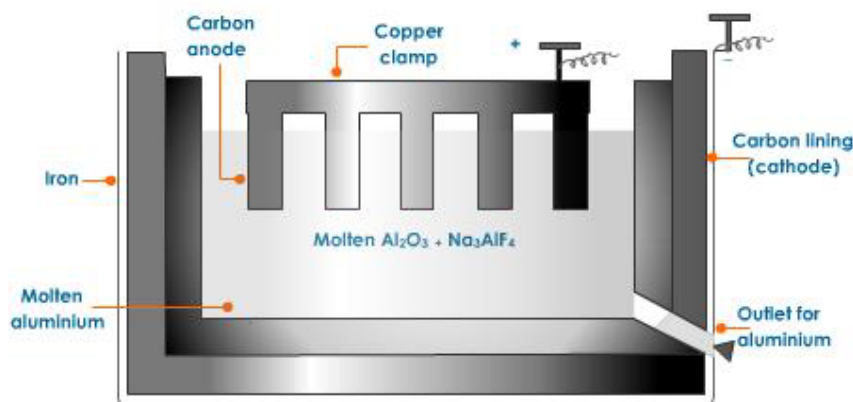

Hall's cell

Pure alumina is dissolved in molten cryolite (Na_3AlF_6) and is electrolyzed in an iron tank lined inside with carbon. Carbon lining serves as cathode while a number of carbon rods dipping in the fused electrolyte serve as anode. Cryolite improves the electrical conductivity of the cell, as alumina is a poor conductor. Moreover, cryolite lowers the melting point of the mixture to about 1250 K. Other impurities such as CaF_2 , NaF and AlF_3 may also be added. The temperature of the electrolyte is maintained between 1200-1300 K.

On passing electric current, aluminium is liberated at the cathode and gets collected at the bottom of the tank from where it is removed. Oxygen liberated at the anode combines with the carbon of the anode to produce carbon monoxide, which either burns or escapes out. The reactions taking place during the electrolysis are:

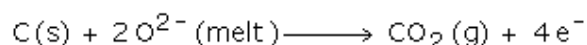
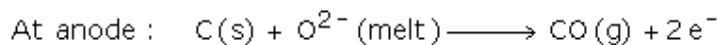

Since during electrolysis the carbon electrodes get consumed they have to be replaced periodically.

Refining of Aluminium (Hoop's process)

The metal obtained in the above step is about 99% pure and for most purposes it is taken as pure metal. However, further purification of aluminium can be carried out by Hoopes process. The cell consists of an iron tank lined with carbon at the bottom. A molten alloy of copper, crude aluminium and silicon is used as the anode. It forms the lower most layer in the cell. The middle layer consists of molten mixture of fluorides, of sodium aluminium and barium (cryolite + BaF_2). The upper most layer consists of molten aluminium. A set of graphite rods dipping in molten aluminium serve as cathode.

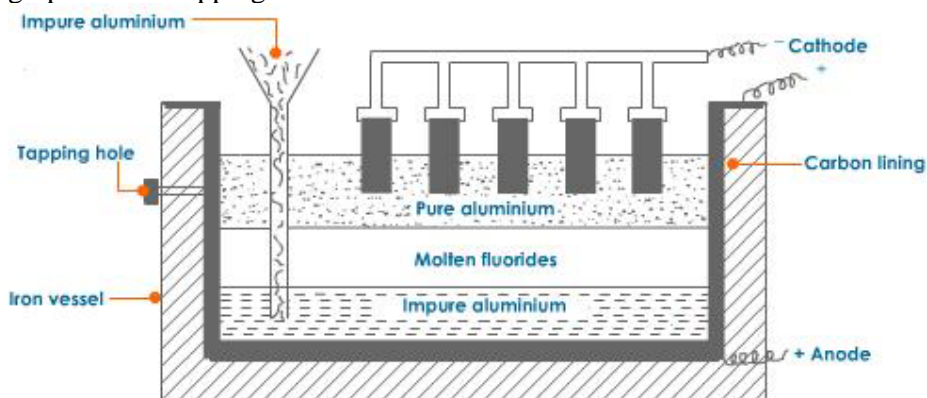

Purification of Aluminium by Hoop's cell

On passing current aluminium ions from the fused electrolyte are discharged at cathode and pure aluminium collects as the top layer. Meanwhile, an equivalent quantity of aluminium from crude alloy at the bottom goes into electrolyte in the middle layer. Crude aluminium is added from time to time and pure aluminium tapped off from the top.

5. Explain the extraction of Mg from its ores. Explain its properties and uses.

Ans: **Magnesium**

Magnesium belongs to group 2 of the periodic table along with other elements like Calcium (Ca), beryllium (Be), strontium (Sr), barium (Ba) and radium (Ra). These elements are called alkaline Earth metals. Due to their smaller size, the electrons are more tightly bound in them and so the first ionization energies are higher than those of the corresponding group 1 elements. The second ionization energies are almost twice the first ionization energies in these elements. Magnesium forms bivalent cations, but they are less electropositive than the alkali elements. In view of the smaller size of the atoms and ions, alkaline earth metals are denser and harder than the alkali metals and have higher melting points.

Occurrence

Magnesium being quite reactive does not occur in the free state in nature but in the combined state.

Minerals of magnesium

Extraction of magnesium

Magnesium metal is strong reducing agent and therefore, cannot be obtained by chemical reduction method. It is extracted by electrolysis of fused anhydrous salts.

A number of methods are available for the extraction of magnesium metal from its ores. The most widely used method is based on the electrolysis of magnesium chloride obtained from the seawater.

Dow's process

This process consists of the following steps:

- Magnesium ions present in the sea water are precipitated as magnesium hydroxide by the addition of slaked lime, Ca(OH)_2 to the sea water.

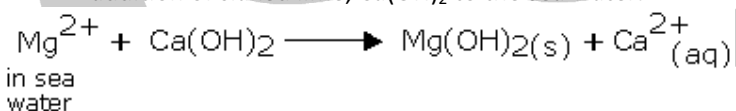

- Magnesium hydroxide is separated and converted to magnesium chloride by treatment with hydrochloric acid.

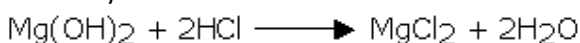

The magnesium chloride is crystallized as $\text{MgCl}_2 \cdot 6\text{H}_2\text{O}$

- Fused magnesium chloride for electrolysis is obtained as follows:

Magnesium chloride hexahydrate is partially dehydrated by passing a current of dry hydrogen chloride gas. The magnesium chloride thus obtained is added to a molten mixture of sodium chloride and calcium chloride (35 : 50 : 15). Magnesium chloride melts under this condition with the loss of water at about 1000 K (700 - 725°C).



The molten mixture of MgCl_2 , NaCl and CaCl_2 is electrolyzed in an iron cell through which an inert gas (or coal gas) flows to avoid any reaction between the liberated metal and oxygen / nitrogen of the air. The cell wall acts as the cathode, while the carbon rod dipping into the melt acts as anode. Magnesium is obtained at the cathode and chlorine is evolved at the anode. This chlorine is used in making hydrochloric acid, which is required for obtaining magnesium chloride.

At cathode:

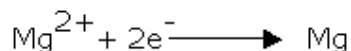

At anode:



The liberated metal being lighter than the electrolyte floats over the surface. Chlorine evolved at anode is obtained as a by-product. Metal of 99.9 per cent purity is obtained by this method.

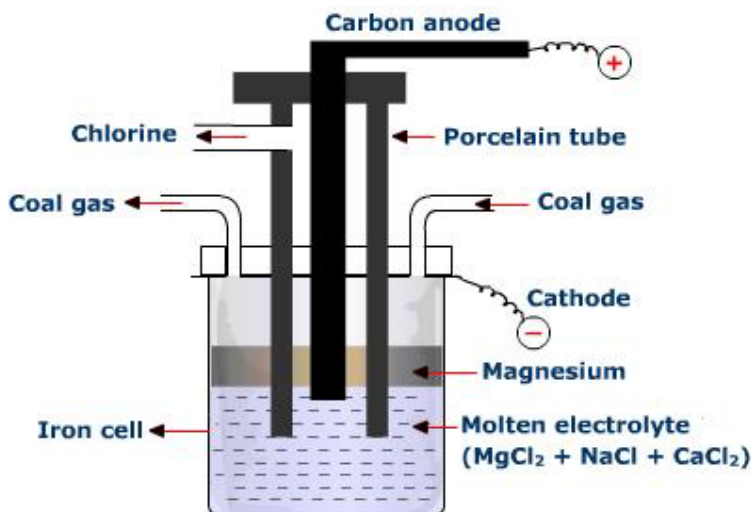

Electrolysis of magnesium chloride

Physical Properties of Metals

- Magnesium is a silvery-white, soft and light metal (density = 1.75 g/mL).
- It melts at 651°C and boils at 1090°C. It sublimes in vacuum at 550°C.
- It is malleable and ductile.
- It is a good conductor of electricity and heat.

Chemical Properties of Magnesium

i) Action of air

Dry air has no effect on magnesium and calcium. In moist air, a thin layer of oxide gets formed on its surface. When heated in air, they burn with a dazzling light giving its oxide and nitride.

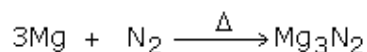

ii) Action of water

Magnesium reacts very slowly with cold water, and slowly with boiling water to give hydrogen.



When heated with steam, magnesium burns to give MgO and H₂.

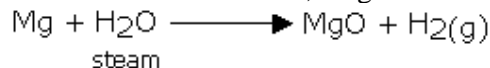

iii) Action of acids

Both magnesium and calcium react with all dilute mineral acids to produce hydrogen.

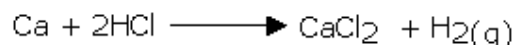
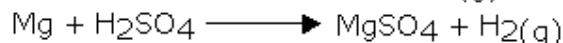



- With dilute nitric acid, magnesium gives ammonium nitrate, and magnesium nitrate.

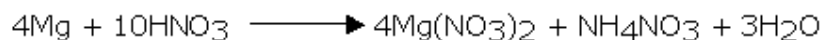

iv) Reducing action

Calcium and magnesium have very high affinity for oxygen. They reduce the oxides of metals and non-metals to the respective element.

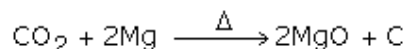
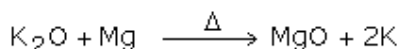

v) With non-metals

Magnesium combines with non-metals on heating.

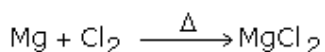
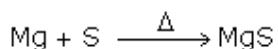

vi) Displacement of less electropositive elements

Mg is highly electropositive; hence it displaces nearly all the metals from their salt solutions.

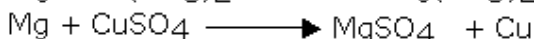

vii) Formation of alkyl magnesium halides

Magnesium reacts with haloalkanes in ether medium, to form alkyl magnesium halide, commonly called as the Grignard's reagent.

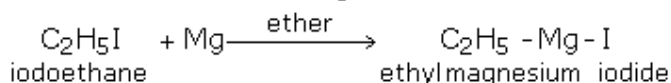
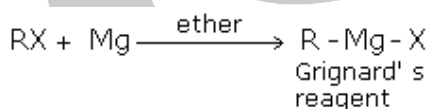

Grignard's reagents are very useful synthetic reagents in organic chemistry.

Uses

- In flash light photography, fire works and signal fires.
- As a reducing agent for the preparation of silicon and boron.
- As a fuse in the aluminothermic process.
- In the manufacture of light and high-tensile alloys such as magnesium aluminium alloy.
- As anodes for corrosion prevention.

6. Explain the extraction of Mg from Dolomite.

Extraction of Magnesium by Electrolysis

Magnesium is relatively active silvery white metal. At slightly below its melting point, it is malleable and ductile and can be drawn into wire or rolled into ribbon in which form it is generally sold. It is a very light metal.

Introduction to extraction of magnesium by electrolysis

Magnesium does not tarnish in dry air but a layer of white oxide is formed on its surface in moist air. The atomic number of Magnesium is 12 and the atomic mass number is 24.305 and has electronic configuration of [Ne] 3s²

Extraction of Magnesium by Electrolysis

The magnesium comes from the name of the mineral magnesite, which in turn is believed to stem from the name Magnesia. The British chemist Humphry Davy discovered the pure element magnesium in 1808.

Magnesium does not occur in the native state. In the combined state it occurs very abundantly in the earth crust. Magnesite, MgCO₃, Dolomite, MgCO₃, CaCO₃, Epsom salt, MgSO₄, 7H₂O Carnalite MgCl₂ KCl.6H₂O

Magnesium is prepared/ extracted on a large scale by the electrolysis of either fused magnesium chloride or magnesia.

The purified carnalite ore is the principal source for this process. A mixture of equal quantities of carnalite and NaCl is fused to a clear liquid at 973K. The alkali chloride prevents hydrolysis of magnesium chloride and increases the conductivity of the fused mass. The electrolysis of the fused mass is carried out in an atmosphere of coal gas in air tight iron cell which can hold 6-7 tonnes of the electrolyte. The temperature of the electrolyte bath is maintained at 970K. The iron cell itself acts as a cathode unlike the anode consists of a carbon or graphite rod surrounded by a porcelain tube through which the liberated chlorine escapes. Molten magnesium being lighter than the electrolyte rises to the surface and is periodically removed with perforated ladle. The electrolysis is carried out in an atmosphere of coal gas so as to avoid the oxidation of molten magnesium. The metal thus obtained is 99.9% pure. It may be further purified by remelting with a flux of anhydrous magnesium chloride and sodium chloride

Reactions for Extraction of Magnesium by Electrolysis

The following are reactions for Extraction of Magnesium by electrolysis

At cathode the reaction is:-

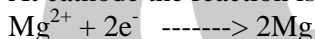

At anode the reaction is:-



7. Explain the extraction of sodium by Castner's process.

Extraction of Sodium:

The metal sodium, was prepared in 1807 by an English chemist, Sir Humphery Davy by electrolysis of fused caustic soda. The method used for extracting sodium metals is,

- Castner's process: By the electrolysis of fused caustic soda.

Castner's process

Molten sodium hydroxide (caustic soda, NaOH) is electrolyzed using an iron cathode and nickel anode. A nickel wire gauze cylinder prevents the electrodes from touching each other. On passing electric current through the melt, sodium is liberated at the cathode and oxygen at the anode. The liberated sodium metal floats over the surface (lighter than fused caustic soda), and collects inside the receiving vessel where hydrogen prevents sodium from oxidation. Excess of the gas escapes from the outlet. Sodium is removed from time to time with the help of perforated spoons and kept under kerosene oil. The various reactions taking place during electrolysis are:

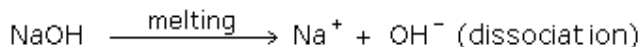

At cathode:

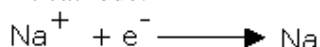

At anode:

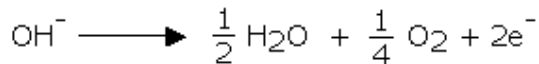

Most of the water formed in the reaction gets evaporated, and the rest is electrolyzed into hydrogen and oxygen. Therefore, metallic sodium and hydrogen are liberated at the cathode and oxygen at the anode.

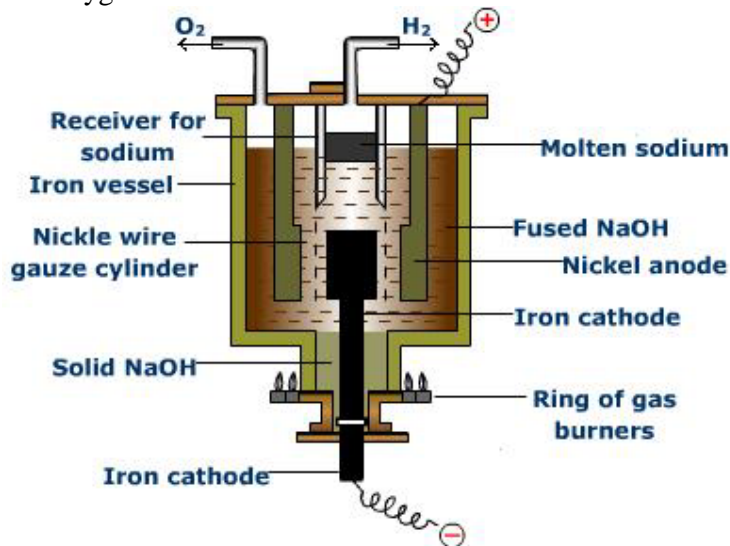

Castner's process

8. Explain the extraction of sodium by Down's process.

The metal sodium was prepared in 1807 by an English chemist, Sir Humphery Davy by electrolysis of fused caustic soda. The method used for extracting sodium metals is,

- Down's process: By the electrolysis of fused sodium chloride.

Down's process

In this process, molten sodium chloride (common salt) is electrolyzed using a graphite anode and a ring shaped iron cathode. The two electrodes are separated by a wire gauge partition to avoid the mixing of sodium and chlorine so formed. As Sodium chloride melts at a very high temperature of 1085 K, a mixture containing sodium chloride, potassium chloride and potassium fluoride ($\text{NaCl} + \text{KCl} + \text{KF}$) is employed. This mixture melts at about 850-875 K.

The reasons for lowering the temperature are:

- It is difficult to maintain a high temperature of 1085K.
- Sodium is volatile at this temperature and so a part of the metal formed may vaporize.
- At this high temperature chlorine produced as a by product corrodes the vessel.
- Metal at this temperature will be in a colloidal state and its separation will be difficult.

On passing electric current, chlorine is liberated at the carbon anode and escapes through the dome shaped steel hood outlet. Sodium rises from the cathode and remains in the wire gauze shell. The sodium produced is in molten state. Being lighter than the electrolyte it rises to the surface. As the level of molten sodium arises, it is forced into the receiver. The process is continuous and fresh salt is introduced to maintain the level of molten electrolyte high enough to allow sodium to rise into the iron pipe. Chemical reactions involved in this process are as follows:

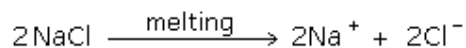

At cathode:

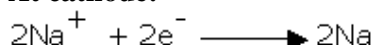

At anode:

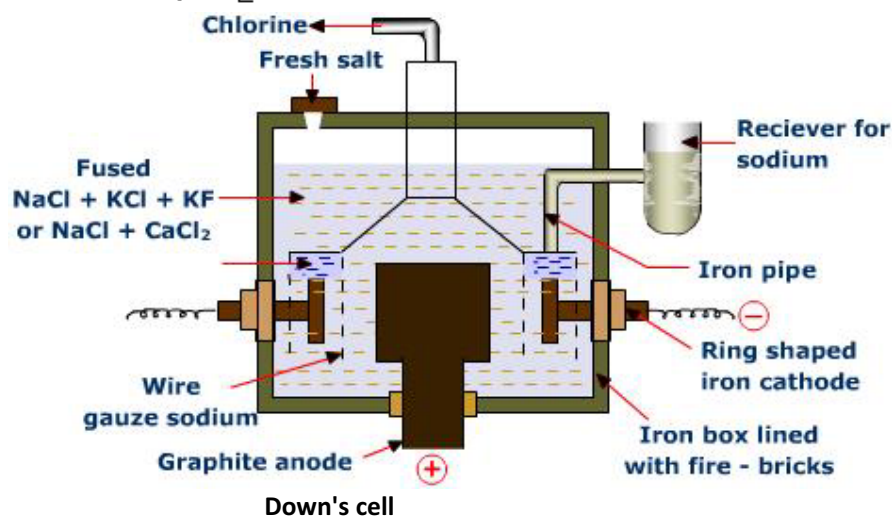

Advantages of Down's process

- Sodium metal obtained has high degree of purity (99.5%).
- The starting material, sodium chloride is very cheap.
- Chlorine is obtained as a useful by-product.

SHORT ANSWER QUESTIONS

1. Explain the purification of bauxite.

Ans: Bauxite contains silicon dioxide (SiO₂), iron oxides and titanium(IV) oxide as impurities. The bauxite ore is digested with a concentrated solution of sodium hydroxide at 473-523 K and 35-36 bar pressure. Aluminium oxide and silica dissolve to form sodium aluminate and sodium silicate respectively leaving behind iron oxide and TiO₂, which are filtered off.

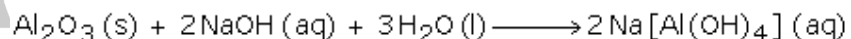

The filtrate containing sodium aluminate and sodium silicate is diluted and seeded with freshly precipitated aluminium hydroxide, which induces the precipitation of aluminium hydroxide leaving behind sodium silicate in solution.

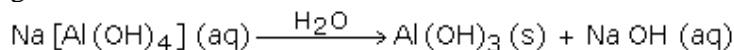

The aluminium hydroxide is filtered dried and calcined at 1473 K to yield pure alumina.

2. Explain Hall-Heroult process of aluminium extraction.

Electrolysis of pure alumina (Hall-Heroult process)

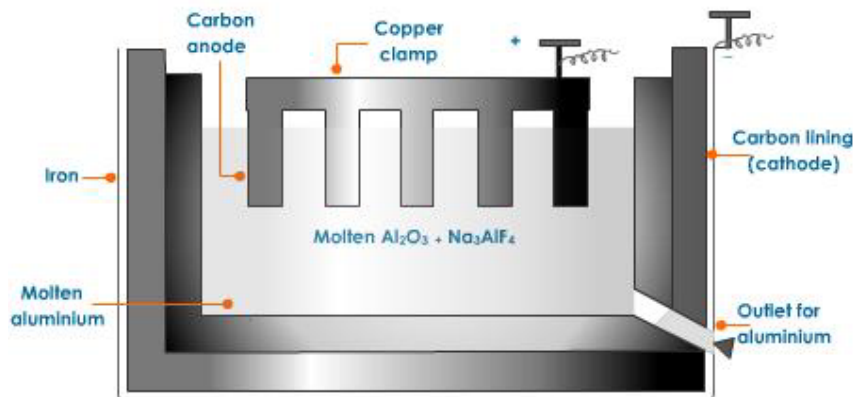

Hall's cell

Pure alumina is dissolved in molten cryolite (Na_3AlF_6) and is electrolyzed in an iron tank lined inside with carbon. Carbon lining serves as cathode while a number of carbon rods dipping in the fused electrolyte serve as anode. Cryolite improves the electrical conductivity of the cell, as alumina is a poor conductor. Moreover, cryolite lowers the melting point of the mixture to about 1250 K. Other impurities such as CaF_2 , NaF and AlF_3 may also be added. The temperature of the electrolyte is maintained between 1200-1300 K.

On passing electric current, aluminium is liberated at the cathode and gets collected at the bottom of the tank from where it is removed. Oxygen liberated at the anode combines with the carbon of the anode to produce carbon monoxide, which either burns or escapes out. The reactions taking place during the electrolysis are:

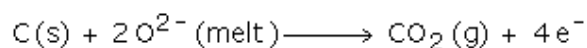
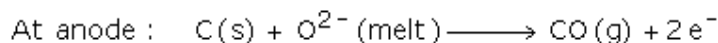

Since during electrolysis the carbon electrodes get consumed they have to be replaced periodically.

3. Explain Hoop's process of extraction of aluminium.

Ans: Refining of aluminium (Hoop's process)

The metal obtained in the above step is about 99% pure and for most purposes it is taken as pure metal. However, further purification of aluminium can be carried out by Hoopes process. The cell consists of an iron tank lined with carbon at the bottom. A molten alloy of copper, crude aluminium and silicon is used as the anode. It forms the lower most layer in the cell. The middle layer consists of molten mixture of fluorides, of sodium aluminium and barium (cryolite + BaF_2). The upper most layer consists of molten aluminium. A set of graphite rods dipping in molten aluminium serve as cathode.

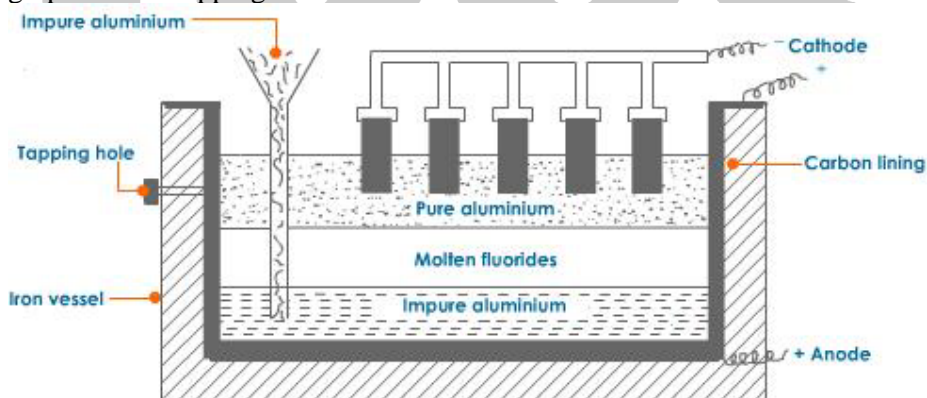

Purification of aluminium by Hoop's cell

On passing current aluminium ions from the fused electrolyte are discharged at cathode and pure aluminium collects as the top layer. Meanwhile, an equivalent quantity of aluminium from crude alloy at the bottom goes into electrolyte in the middle layer. Crude aluminium is added from time to time and pure aluminium tapped off from the top.

4. Give the names of important ores of Al and Mg.

a) Magnesium

i) Magnesite MgCO_3

- ii) Dolomite $\text{MgCO}_3 \cdot \text{CaCO}_3$
- iii) Epsomite or Epsom salt $\text{MgSO}_4 \cdot 7\text{H}_2\text{O}$
- iv) Caranallite $\text{MgCl}_2 \cdot \text{KCl} \cdot 6\text{H}_2\text{O}$
- v) Kieserite $\text{MgSO}_4 \cdot \text{H}_2\text{O}$
- vi) Kainite $\text{K}_2\text{SO}_4 \cdot \text{MgSO}_4 \cdot \text{MgCl}_2 \cdot 6\text{H}_2\text{O}$

b) Aluminium

- i) Bauxite $\text{Al}_2\text{O}_3 \cdot 2\text{H}_2\text{O}$
- ii) Kaolin $\text{Al}_2\text{O}_3 \cdot 2\text{SiO}_2 \cdot 2\text{H}_2\text{O}$
- iii) Cryolite Na_3AlF_6
- iv) Felspar $\text{K}_2\text{O} \cdot \text{Al}_2\text{O}_3 \cdot 6\text{SiO}_2$

5. Write the important uses of aluminium

Ans:

- Aluminium is used in packaging that includes drink cans, bottle tops, foil wrappings and foil containers. Food packed within this protects it from the changes caused due to exposure of the outer environment.
- The natural resistance to corrosion renders it useful in packaging. The aluminium oxide forms a protective layer as against the destructive layer formed by iron. Aluminium is impermeable and even in the shape of thin rolls; it traps the aroma and taste of the food. Since the metal is odourless and is non-toxic, thus making it perfect for packaging.
- Aluminium with its strength to weight ratio has a number of uses in transport industry. The alloys of aluminium use other elements to remove dislocations in its structure for the increase in its strength. Its lightweight property gives fuel efficiency when it is used in cars, trains and boats.
- The ductility of aluminium is higher than that of copper rendering them to be used in power lines and since aluminium is corrosion resistant, long distance distribution of electrical lines use aluminium wires.
- TV aerials, satellite dishes and the standard bulb bases are prepared of aluminium.
- Aluminium is extremely versatile and it is easily moulded, curved, tapered, bonded or cut to any desired shape. Buildings with insulated aluminium cladding are thermally efficient.
- Aluminium is used in the preparation of household products like kitchen appliances, utensils, indoor and outdoor furniture and in the making of tennis bats and golf clubs.

6. Write a note on the extraction of sodium from sodium hydroxide

Castner's process:

Molten sodium hydroxide (caustic soda, NaOH) is electrolyzed using an iron cathode and nickel anode. A nickel wire gauze cylinder prevents the electrodes from touching each other. On passing electric current through the melt, sodium is liberated at the cathode and oxygen at the anode. The liberated sodium metal floats over the surface (lighter than fused caustic soda), and collects inside the receiving vessel where hydrogen prevents sodium from oxidation. Excess of the gas escapes from the outlet. Sodium is removed from time to time with the help of perforated spoons and kept under kerosene oil. The various reactions taking place during electrolysis are:

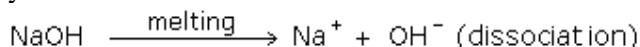

At cathode:

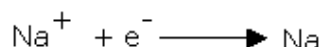

At anode:

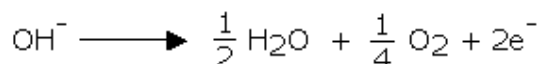

Most of the water formed in the reaction gets evaporated, and the rest is electrolyzed into hydrogen and oxygen. Therefore, metallic sodium and hydrogen are liberated at the cathode and oxygen at the anode.

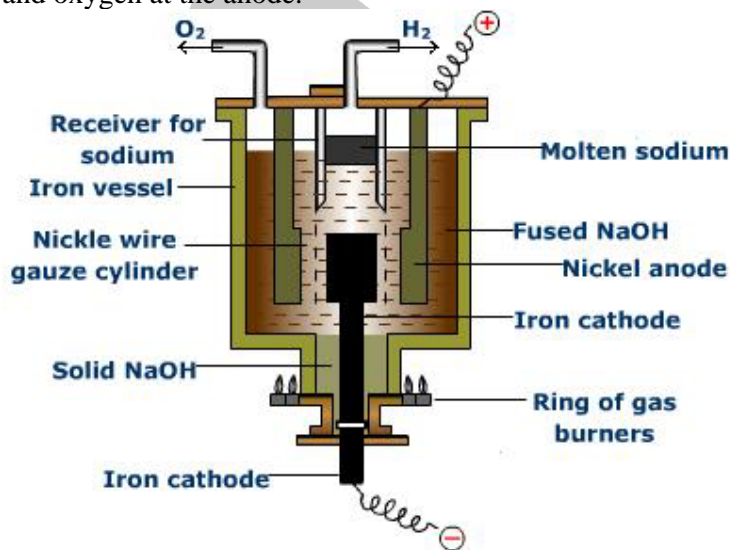

Castners process

7. Write a note on the extraction of sodium using down's process.

Down's process

In this process, molten sodium chloride (common salt) is electrolyzed using a graphite anode and a ring shaped iron cathode. The two electrodes are separated by a wire gauge partition to avoid the mixing of sodium and chlorine so formed. As Sodium chloride melts at a very high temperature of 1085 K, a mixture containing sodium chloride, potassium chloride and potassium fluoride (NaCl + KCl + KF) is employed. This mixture melts at about 850-875 K. The reasons for lowering the temperature are:

- It is difficult to maintain a high temperature of 1085K.
- Sodium is volatile at this temperature and so a part of the metal formed may vaporize.
- At this high temperature chlorine produced as a by product corrodes the vessel.
- Metal at this temperature will be in a colloidal state and its separation will be difficult.

On passing electric current, chlorine is liberated at the carbon anode and escapes through the dome shaped steel hood outlet. Sodium rises from the cathode and remains in the wire gauze shell. The sodium produced is in molten state. Being lighter than the electrolyte it rises to the surface. As the level of molten sodium arises, it is forced into the receiver. The process is continuous and fresh salt is introduced to maintain the level of molten electrolyte high enough to allow sodium to rise into the iron pipe. Chemical reactions involved in this process are as follows:

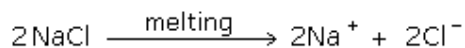

At cathode:

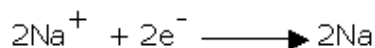

At anode:

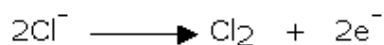

Advantages of Down's process

- Sodium metal obtained has high degree of purity (99.5%).
- The starting material, sodium chloride is very cheap.
- Chlorine is obtained as a useful by-product.

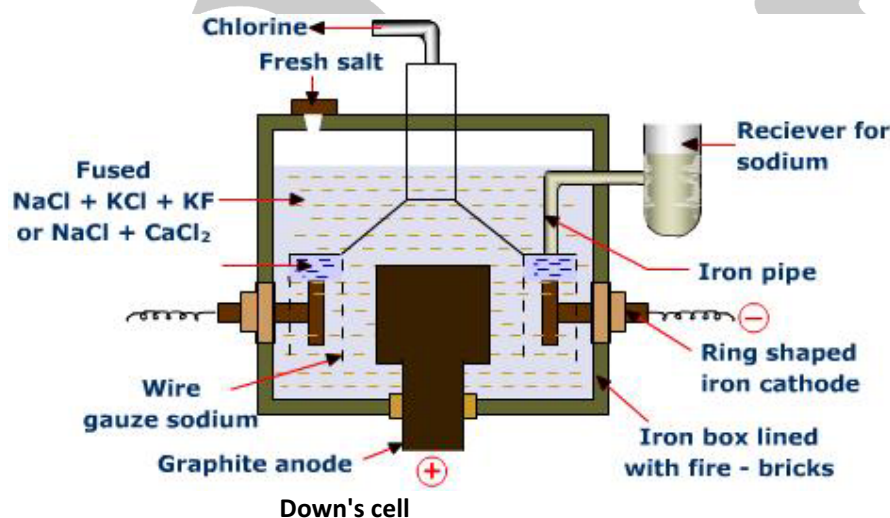

VERY SHORT ANSWER QUESTIONS

1. What metal is purified by cupellation?

Silver metal is purified by cupellation

2. Explain polling

Oxide impurity of impure metals can be purified by this method. Poles of green wood are used to stir the molten crude metal sample. The hydrocarbon organic matter in the poles acts as a reducing agent and reduces the oxide impurities. This method is used for refining copper.

3. **Define flux.**

An outside substance added to lower the melting point is known as flux. The flux combines with gangue to form slag.

4. **Mention any two furnaces that are generally used in metallurgical processes.**

Blast furnace and reverberatory furnace.

5. **What do reactions in a blast furnace take place?**

Reactions in a blast furnace take place in the body of the furnace

6. **Can Zn exist in native state? Why or why not..**

Zinc does not occur in the native form since it is a reactive metal. However, in the combined state, zinc is widely distributed

7. **Give the names and formulae of Zn ores.**

Zinc Ores

The important ores of zinc are

- i) Zinc blende, ZnS
- ii) Calamine, ZnCO₃
- iii) Zincite, ZnO

The chief ore of Zinc is Zinc blende

8. **Explain briefly the extraction of Zn.**

The extraction of Zinc from Zinc blende involves the following steps.

1. Concentration

The ore is crushed and then concentrated by froth-floatation process.

2. Roasting

The concentrated ore is then roasted in the presence of excess of air at about 1200 K.

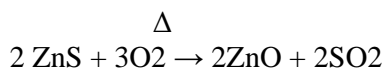

3. Reduction

Zinc oxide is mixed with powdered coke and heated to 1673 K in a fire clay retort, in which ZnO is reduced to zinc metal.

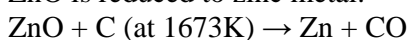

9. **How Zn is purified?**

Purification

Zinc is purified by electrolytic refining. In this process, Impure Zinc is anode and cathode is of pure

thin sheet of Zinc. The electrolyte is ZnSO₄ solution containing a little of dil.H₂SO₄. On passing electric current, pure zinc get deposited at the cathode.

10. Write the uses of Zn.

Uses of zinc

1. It is widely used for galvanizing iron sheets.
2. It is used in the extraction of gold and silver by the cyanide process.
3. Zinc plates and rods are used in batteries and dry cells.
4. Zinc dust and granulated zinc are used in laboratory as reducing agents

11. What is the purpose of adding KCl and NaCl to anhydrous MgCl₂?

Ans: A mixture of equal quantities of carnallite and NaCl is fused to a clear liquid at 973K. The alkali chloride prevents hydrolysis of magnesium chloride and increases the conductivity of the fused mass.

12. What are the reactions that take place in electrolysis of MgCl₂?

The following are reactions for Extraction of Magnesium by electrolysis

At cathode the reaction is:-



At anode the reaction is:-



13. What are the ores of sodium?

- Albite (soda feldspar) NaAlSi₃O₈
- Borax (as tincal) Na₂B₂O₇.10H₂O
- Glauber's salt Na₂SO₄.10H₂O
- Sodium chloride, (common salt) found as rock salt, in sea water and in lakes.
- Sodium nitrate (NaNO₃) as Chile saltpeter.

14. What are the advantages of Down's process of extraction of Sodium?

Advantages of Down's process:

- Sodium metal obtained has high degree of purity (99.5%).
- The starting material, sodium chloride is very cheap.
- Chlorine is obtained as a useful by-product